

Bronze Gate Valves Illustrated Index

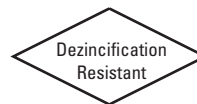

<p>Bronze Gate Valve Screw-in Bonnet 125 lb. SWP 200 lb. CWP</p>  <p>T or S-111 Rising Stem • Solid Wedge Sizes 1/4" thru 3" Threaded or Solder Ends Page 6</p>	<p>Bronze Gate Valve Screw-in Bonnet 125 lb. SWP 200 lb. CWP</p>  <p>T or S-113 Non-Rising Stem • Solid Wedge Sizes 1/4" thru 3" Threaded or Solder Ends Page 7</p>	<p>Bronze Hose Gate Valve Screw-in Bonnet 125 lb. SWP 200 lb. CWP</p>  <p>T-113-HC Non-Rising Stem • Solid Wedge Sizes 1/2" thru 1 1/2" Threaded Ends Page 8</p>	<p>Bronze Gate Valve Block Design • Union Bonnet 125 lb. SWP 200 lb. CWP</p>  <p>T-124 Rising Stem • Solid Wedge Sizes 1/4" thru 3" Threaded Ends Page 9</p>
<p>Bronze Gate Valve Block Design • Screw-in Bonnet 150 lb. SWP 300 lb. CWP</p>  <p>T-131 Rising Stem • Solid Wedge Sizes 1/4" thru 3" Threaded Ends Page 10</p>	<p>Bronze Gate Valve Block Design • Screw-in Bonnet 150 lb. SWP 300 lb. CWP</p>  <p>T-133 Non-Rising Stem • Solid Wedge Sizes 1/4" thru 3" Threaded Ends Page 11</p>	<p>Bronze Gate Valve Block Design • Union Bonnet 150 lb. SWP 300 lb. CWP</p>  <p>T or S-134 Rising Stem • Solid Wedge Sizes 1/4" thru 3" Size 4" Bolted Bonnet Threaded or Solder Ends Page 12, 13</p>	<p>Bronze Gate Valve Block Design • Union Bonnet 150 lb. SWP 300 lb. CWP</p>  <p>T-135 Rising Stem • Split Wedge Sizes 1/4" thru 3" Threaded or Solder Ends Page 14</p>
<p>Bronze Gate Valve Block Design • Union Bonnet 150 lb. SWP 300 lb. CWP</p>  <p>T or S-136 Non-Rising Stem • Solid Wedge Sizes 1/4" thru 3" Size 4" Bolted Bonnet Threaded or Solder Ends Page 15, 16</p>	<p>Bronze Gate Valve Block Design • Union Bonnet 200 lb. SWP 400 lb. CWP</p>  <p>T-154-A Rising Stem • Solid Wedge Sizes 1/4" thru 2" Threaded Ends Page 17</p>	<p>Bronze Gate Valve Block Design • Union Bonnet 300 lb. SWP 600 lb. CWP</p>  <p>T-174-A or SS Bronze or SS Seats Rising Stem • Solid Wedge Sizes 1/4" thru 2" Threaded Ends Page 18</p>	<p>Bronze Gate Valve Block Design • Union Bonnet 300 lb. SWP 600 lb. CWP</p>  <p>T-176-A or SS Bronze or SS Seats Non-Rising Stem • Solid Wedge Sizes 1/4" thru 2" Threaded Ends Page 19</p>

Class 125 Bronze Gate Valves

Screw-in Bonnet • Rising Stem • Solid Wedge

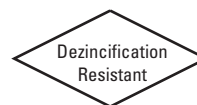

125 PSI/8.6 Bar Saturated Steam to 353° F/178° C
200 PSI/13.8 Bar Non-Shock Cold Working Pressure♦

CONFORMS TO MSS SP-80

MATERIAL LIST

PART	SPECIFICATION
1. Handwheel Nut	Zinc Plated Steel with Clear Chromate
2. Identification Plate	Aluminum
3. Handwheel	Malleable Iron ASTM A 47
4. Stem	Silicon Bronze ASTM B 371 Alloy C69400 or ASTM B 99 Alloy C65100
5. Packing Nut	Bronze ASTM B 62 or ASTM B 584 Alloy C84400 or Brass ASTM B 16
6. Packing Gland	Bronze ASTM B 62 or ASTM B 584 Alloy C84400 or Brass ASTM B 16
7. Packing	Aramid Fibres with Graphite
8. Bonnet	Bronze ASTM B 62
9. Body	Bronze ASTM B 62
10. Wedge	Bronze ASTM B 62



T-111
Threaded



S-111
Solder

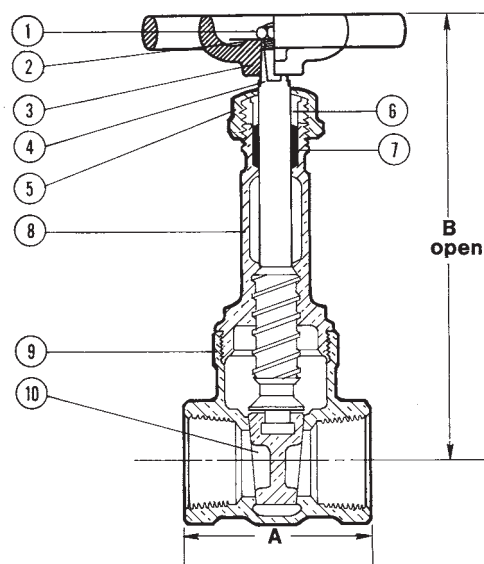

T-111
NPT x NPT

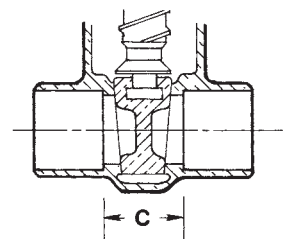

S-111
C x C

DIMENSIONS—WEIGHTS—QUANTITIES

Size	Dimensions						Weights				Master Ctn. Qty.		
	A		B		C		T-111		S-111		T-111	S-111	
In.	mm.	In.	mm.	In.	mm.	In.	mm.	Lbs.	Kg.	Lbs.	Kg.		
† ¼	8	1.69	43	4.63	117	.69	18	0.79	0.36	x	x	50	50
† ⅜	10	1.69	43	4.63	117	.69	18	0.76	0.35	0.70	0.32	50	50
† ½	15	1.94	49	4.81	122	.75	19	0.87	0.40	0.73	0.33	50	50
¾	20	2.06	54	5.81	148	.88	22	1.19	0.54	1.07	0.49	50	50
1	25	2.44	62	7.09	180	1.00	25	1.98	0.90	1.77	0.80	30	30
1¼	32	2.63	67	8.13	206	1.19	32	2.66	1.21	2.52	1.14	20	20
1½	40	2.88	72	9.81	249	1.25	33	3.76	1.70	3.42	1.55	10	10
2	50	3.06	78	11.56	294	1.31	34	5.56	2.52	5.23	2.37	10	10
2½	65	4.13	105	14.31	364	1.81	46	10.81	4.90	9.63	4.37	4	4
3	80	4.50	114	16.50	419	1.94	49	15.49	7.02	13.92	6.31	2	4

† No packing gland, packing only in these sizes.

x Not available this size.

Freezing Weather Precaution – Subsequent to testing a piping system, valves should be in an open position to allow complete drainage.

♦ For detailed Operating Pressure, refer to Pressure Temperature Chart on page 107.

Class 125 Bronze Gate Valves

Screw-in Bonnet • Non-Rising Stem • Solid Wedge

125 PSI/8.6 Bar Saturated Steam to 353° F/178° C
200 PSI/13.8 Bar Non-Shock Cold Working Pressure♦

CONFORMS TO MSS SP-80

MATERIAL LIST

PART	SPECIFICATION
1. Handwheel Nut	Zinc Plated Steel with Clear Chromate
2. Identification Plate	Aluminum
3. Handwheel	a. Malleable Iron ASTM A 47 (T-113) b. Bronze (T-113-BHW) c. Bronze Cross (T-113-K)
4. Stem	Silicon Bronze ASTM B 371 Alloy C69400 or ASTM B99 Alloy C65100
5. Packing Nut	Bronze ASTM B 62 or ASTM B 584 Alloy C84400 or Brass ASTM B 16
6. Packing Gland	Bronze ASTM B 62 or ASTM B 584 Alloy C84400 or Brass ASTM B 16
7. Packing	Aramid Fibres with Graphite
8. Stuffing Box	Bronze ASTM B 62
9. Bonnet	Bronze ASTM B 62
10. Body	Bronze ASTM B 62
11. Wedge	Bronze ASTM B 62

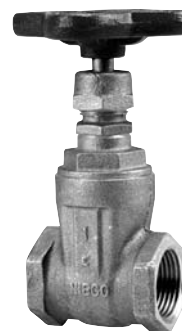
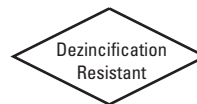

T-113
Threaded

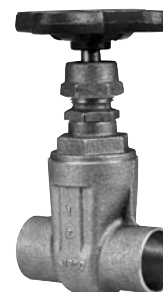

S-113
Solder

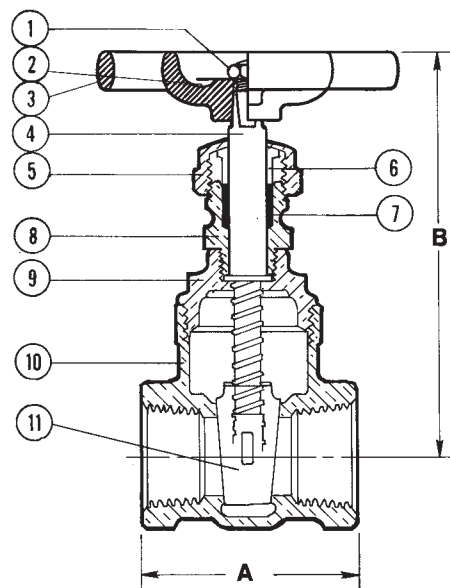

T-113
NPT x NPT

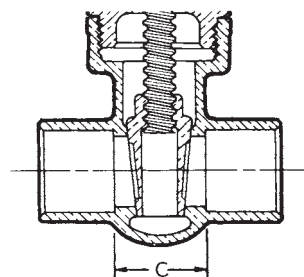

S-113
C x C

DIMENSIONS—WEIGHTS—QUANTITIES

Size	Dimensions						T-113		S-113		Master Ctn. Qty.	
	In.	mm.	In.	mm.	In.	mm.	Lbs.	Kg.	Lbs.	Kg.		
¼ †	8	1.69	43	3.38	86	x	x	0.74	0.33	x	x	50
⅜ †	10	1.69	43	3.38	86	.69	18	0.71	0.32	0.65	0.29	50
½ †	15	1.94	49	3.63	92	.75	19	0.82	0.37	0.67	0.31	50
¾	20	2.06	54	3.91	99	.88	22	1.10	0.50	0.99	0.45	50
1	25	2.44	62	4.69	119	1.00	25	1.82	0.82	1.60	0.72	30
1¼	32	2.63	67	5.22	133	1.19	32	2.40	1.09	2.25	1.02	20
1½	40	2.88	72	6.25	159	1.25	33	3.51	1.59	3.17	1.44	10
2	50	3.06	78	7.06	179	1.31	34	4.93	2.24	4.60	2.09	10
2½	65	4.13	105	8.41	224	1.81	46	9.96	4.52	8.78	3.98	5
3	80	4.50	114	10	254	1.94	49	14.40	6.53	12.84	5.82	4

† No packing gland, packing only in these sizes.

x Not available this size.

Freezing Weather Precaution – Subsequent to testing a piping system, valves should be in an open position to allow complete drainage.

♦ For detailed Operating Pressure, refer to Pressure Temperature Chart on page 107.

Class 125 Bronze Gate Valves

Screw-in Bonnet • Non-Rising Stem • Solid Wedge

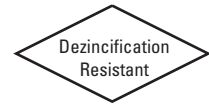

125 PSI/8.6 Bar Saturated Steam to 353° F/178° C
200 PSI/13.8 Bar Non-Shock Cold Working Pressure♦

CONFORMS TO MSS SP-80

MATERIAL LIST

PART	SPECIFICATION
1. Handwheel Nut	Zinc Plated Steel with Clear Chromate
2. Identification Plate	Aluminum
3. Handwheel	Malleable Iron ASTM A 47
4. Stem	Silicon Bronze ASTM B 371 Alloy 69400
5. Packing Nut	Sintered Bronze ASTM B 438 70 Grade I Type II or Brass ASTM B 16
6. Packing Gland	Sintered Bronze ASTM B 438 70 Grade I Type II or Brass ASTM B 16
7. Packing	Aramid Fibres with Graphite
8. Stuffing Box	Bronze ASTM B 62
9. Bonnet	Bronze ASTM B 62
10. Body	Bronze ASTM B 62
11. Wedge	Bronze ASTM B 62
*12. Hose Cap	Bronze ASTM B 62
13. Hose Cap Gasket	Rubber
14. Safety Chain	Brass

NOTE: Valve available less cap and chain – consult factory.

* ½ – 1 is 11½ threads per inch

1¼–1½ is 9 threads per inch

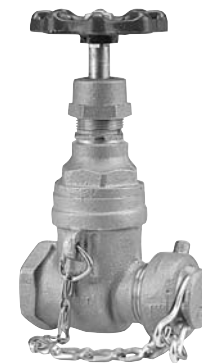

T-113-HC
Threaded x ANFH

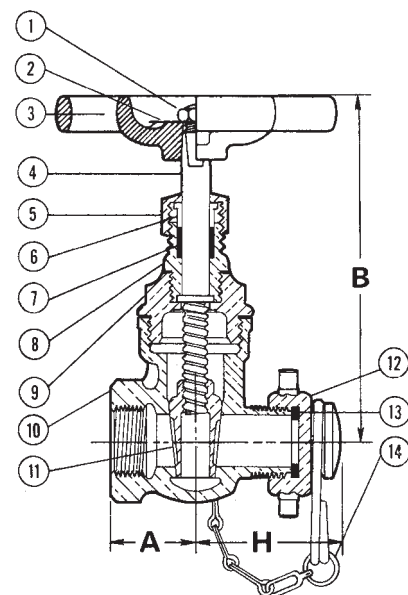

T-113-HC
NPT x ANFH

DIMENSIONS—WEIGHTS—QUANTITIES

Size		Dimensions				H		T-113-HC		Master Ctn. Qty.
In.	mm.	A		B		In.	mm.	Lbs.	Kg.	
½ x ¾H	15 x 20H	1.13	29	4.44	113	2.06	52	1.52	0.69	30
¾ x ¾H	20 x 20H	1.25	32	5.06	129	2.13	54	1.84	0.84	20
1 x 1H	25 x 25H	1.44	37	5.88	149	2.38	60	2.93	1.33	20
1¼ x 1¼H	32 x 32H	1.56	40	6.63	168	2.75	70	4.27	1.94	10
1½ x 1½H	40 x 40H	1.69	43	7.09	180	2.94	75	5.75	2.61	10

Freezing Weather Precaution – Subsequent to testing a piping system, valves should be in an open position to allow complete drainage.

♦ For detailed Operating Pressure, refer to Pressure Temperature Chart on page 107.

Class 125 Bronze Gate Valves

Block Pattern • Union Bonnet • Rising Stem • Solid Wedge

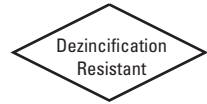

125 PSI/8.6 Bar Saturated Steam to 353° F/178° C
200 PSI/13.8 Bar Non-Shock Cold Working Pressure♦

CONFORMS TO MSS SP-80

MATERIAL LIST

PART	SPECIFICATION
1. Handwheel Nut	Zinc Plated Steel with Clear Chromate
2. Identification Plate	Aluminum
3. Handwheel	Malleable Iron ASTM A 47
4. Stem	Silicon Bronze ASTM B 371 Alloy C69400 or ASTM B 99 Alloy C65100
5. Packing Nut	Bronze ASTM B 62 or ASTM B 584 Alloy C84400 or Brass ASTM B 16
6. Packing Gland	Bronze ASTM B 62 or ASTM B 584 Alloy C84400 or Brass ASTM B 16
7. Packing	Aramid Fibres with Graphite
8. Bonnet	Bronze ASTM B 62
*9. Union Nut	Bronze ASTM B 62
10. Body	Bronze ASTM B 62
11. Wedge	Bronze ASTM B 62

* Sizes ¼", ⅜", ½" ASTM B 124 Alloy C37700.

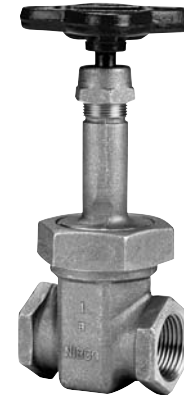

T-124
Threaded

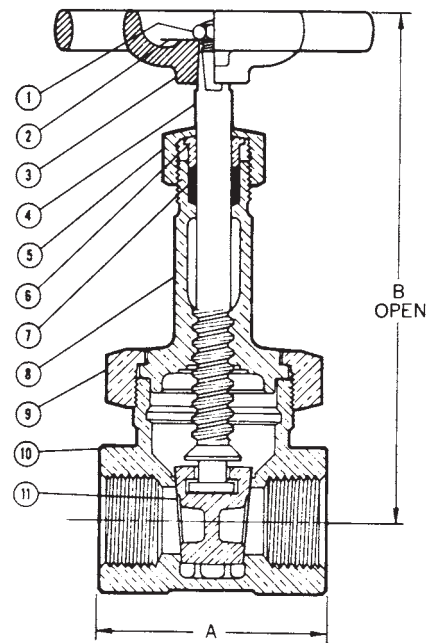

T-124
NPT x NPT

DIMENSIONS—WEIGHTS—QUANTITIES

Size	Dimensions				T-124		Master Ctn. Qty.
	In.	mm.	In.	mm.	Lbs.	Kg.	
¼	8	1.88	48	4.81	122	1.08 0.49	50
⅜	10	2.06	52	4.81	122	1.12 0.51	50
½	15	2.31	59	5.38	137	1.41 0.64	40
¾	20	2.44	62	6.31	160	2.12 0.96	30
1	25	2.88	73	7.56	192	3.07 1.39	20
1¼	32	3.13	83	8.88	226	4.41 2.00	10
1½	40	3.38	86	10.25	260	5.95 2.70	10
2	50	3.88	99	12.50	318	9.82 4.45	6
2½	65	4.75	121	14.69	373	15.41 6.99	4
3	80	5.19	132	16.75	426	21.92 9.94	2

Freezing Weather Precaution – Subsequent to testing a piping system, valves should be in an open position to allow complete drainage.

♦ For detailed Operating Pressure, refer to Pressure Temperature Chart on page 107.

Class 150 Bronze Gate Valves

Block Pattern • Screw-in Bonnet • Rising Stem • Solid Wedge

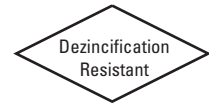

150 PSI/10.3 Bar Saturated Steam to 366° F/185° C
300 PSI/20.7 Bar Non-Shock Working Pressure♦

CONFORMS TO MSS SP-80

MATERIAL LIST

PART	SPECIFICATION
1. Handwheel Nut	Zinc Plated Steel with Clear Chromate
2. Identification Plate	Aluminum
3. Handwheel	Malleable Iron ASTM A 47
4. Stem	Silicon Bronze ASTM B-371 Alloy C69400 or ASTM B 99 Alloy C65100
5. Packing Nut	Bronze ASTM B 62 ASTM B 584 Alloy C84400 or Brass ASTM B 16
6. Packing Gland	Bronze ASTM B 62 ASTM B 584 Alloy C84400 or Brass ASTM B 16
7. Packing	Bronze ASTM B 62
8. Bonnet	Bronze ASTM B 62
9. Body	Bronze ASTM B 62
10. Wedge	Bronze ASTM B 62



T-131
Threaded

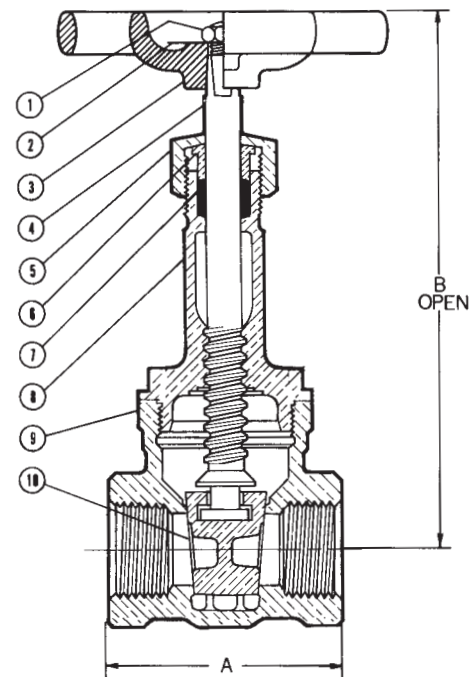

T-131
NPT x NPT

DIMENSIONS—WEIGHTS—QUANTITIES

Size	Dimensions				T-131		Master Ctn. Qty.	
	A		B		Lbs.	Kg.		
In.	mm.	In.	mm.	In.	mm.			
¼	8	1.88	48	4.81	122	1.01	0.46	50
⅜	10	2.06	52	4.81	122	1.04	0.47	50
½	15	2.31	59	5.38	137	1.30	0.59	40
¾	20	2.44	62	6.31	160	1.95	0.88	30
1	25	2.88	73	7.56	192	2.85	1.29	20
1¼	32	3.13	83	8.88	226	4.23	1.92	10
1½	40	3.38	86	10.25	260	5.85	2.66	10
2	50	3.88	99	12.50	318	9.63	4.37	6
2½	65	4.75	121	14.69	373	14.95	6.78	4
3	80	5.19	132	16.75	426	20.70	9.39	2

Freezing Weather Precaution – Subsequent to testing a piping system, valves should be in an open position to allow complete drainage.

♦ For detailed Operating Pressure, refer to Pressure Temperature Chart on page 107.

Class 150 Bronze Gate Valves

Block Pattern • Screw-in Bonnet • Non-Rising Stem • Solid Wedge

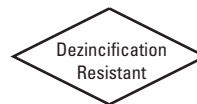

150 PSI/10.3 Bar Saturated Steam to 366° F/185° C
300 PSI/20.7 Bar Non-Shock Cold Working Pressure♦

CONFORMS TO MSS SP-80

MATERIAL LIST

PART	SPECIFICATION
1. Handwheel Nut	Zinc Plated Steel with Clear Chromate
2. Identification Plate	Aluminum
3. Handwheel	Malleable Iron ASTM A 47
4. Stem	Silicon Bronze ASTM B 371 Alloy C69400 or ASTM B 99 Alloy C65100
5. Packing Nut	Bronze ASTM B 62 or ASTM B 584 Alloy C84400 or Brass ASTM B 62
6. Packing Gland	Bronze ASTM B 62 or ASTM B 584 Alloy C84400 or Brass ASTM B 16
7. Packing	Aramid Fibres with Graphite
8. Stuffing Box	Bronze ASTM B 62
9. Bonnet	Bronze ASTM B 62
10. Body	Bronze ASTM B 62
11. Wedge	Bronze ASTM B 62

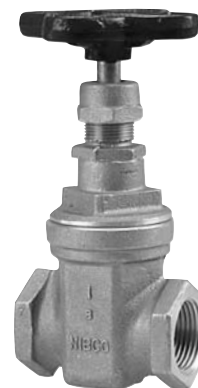

T-133
Threaded

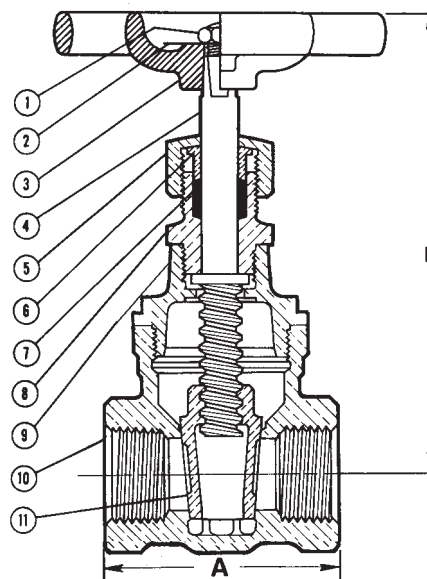

T-133
NPT x NPT

DIMENSIONS—WEIGHTS—QUANTITIES

Size	Dimensions				T-133		Master Ctn. Qty.	
	In.	mm.	A	B	Lbs.	Kg.		
1/4	8	1.88	48	3.88	98	1.02	0.46	50
3/8	10	2.06	52	3.88	98	1.05	0.48	50
1/2	15	2.31	59	4.19	106	1.25	0.57	40
3/4	20	2.44	62	4.63	117	1.85	0.84	30
1	25	2.88	73	5.44	138	2.66	1.21	20
1 1/4	32	3.13	83	6.06	154	3.95	1.79	10
1 1/2	40	3.38	86	7.13	181	5.37	2.43	10
2	50	3.88	99	8.31	211	8.77	3.98	6
2 1/2	65	4.75	121	9.50	241	13.40	6.08	4
3	80	5.19	132	10.44	265	18.29	8.30	2

Freezing Weather Precaution – Subsequent to testing a piping system, valves should be in an open position to allow complete drainage.

♦ For detailed Operating Pressure, refer to Pressure Temperature Chart on page 107.

Class 150 Bronze Gate Valves

Block Pattern • Union Bonnet • Rising Stem • Solid Wedge

150 PSI/10.3 Bar Saturated Steam to 366° F/185° C
300 PSI/20.7 Bar Non-Shock Cold Working Pressure♦

CONFORMS TO MSS SP-80

MATERIAL LIST

PART	SPECIFICATION
1. Handwheel Nut	Zinc Plated Steel with Clear Chromate
2. Identification Plate	Aluminum
3. Handwheel	Malleable Iron ASTM A 47
4. Stem	Silicon Bronze ASTM B 371 Alloy C69400 or ASTM B 99 Alloy C65100
5. Packing Nut	Bronze ASTM B 62 or ASTM B 584 Alloy C84400 or Brass ASTM B 16
6. Packing Gland	Bronze ASTM B 62 or ASTM B 584 Alloy C84400 or Brass ASTM B 16
7. Packing	Aramid Fibres with Graphite
8. Bonnet	Bronze ASTM B 62
9. Union Nut	Bronze ASTM B 62
10. Body	Bronze ASTM B 62
11. Wedge	Bronze ASTM B 62

DIMENSIONS—WEIGHTS—QUANTITIES

Size	Dimensions						T-134		S-134		Master Ctn. Qty.
	A		B		C		Lbs.	Kg.	Lbs.	Kg.	
In.	mm.	In.	mm.	In.	mm.	In.	mm.	Lbs.	Kg.	Lbs.	Kg.
¼	8	1.88	48	4.81	122	x	x	1.08	0.49	x	x
⅜	10	2.06	52	4.81	122	1.00	26	1.12	0.51	1.02	0.46
½	15	2.31	59	5.38	137	1.13	29	1.41	0.64	1.29	0.58
¾	20	2.44	62	6.31	160	1.19	30	2.12	0.96	1.99	0.90
1	25	2.88	73	7.56	192	1.38	35	3.07	1.39	2.93	1.33
1¼	32	3.13	83	8.88	226	1.50	38	4.41	2.00	4.14	1.88
1½	40	3.38	86	10.25	260	1.63	41	5.95	2.70	5.69	2.58
2	50	3.88	99	12.50	318	1.94	49	9.82	4.45	9.53	4.32
2½	65	4.75	121	14.69	373	2.31	59	15.41	6.99	14.66	6.65
3	80	5.19	132	16.75	426	2.50	64	21.92	9.94	20.07	9.10

x Not available this size.

Dezincification Resistant



T-134
Threaded



S-134
Solder

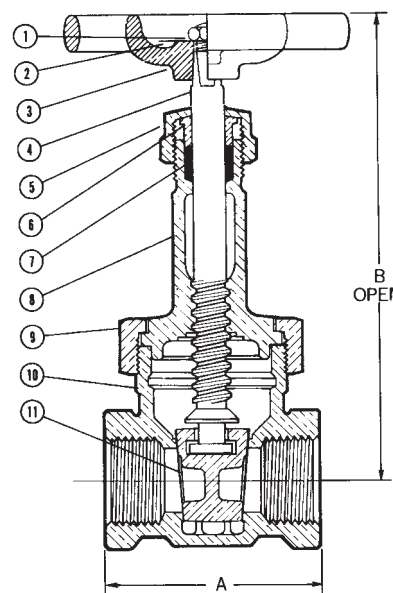

T-134
NPT x NPT

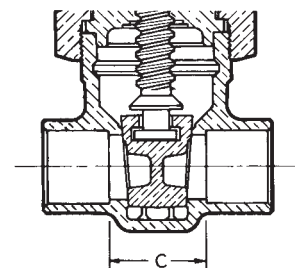

S-134
C x C

Freezing Weather Precaution – Subsequent to testing a piping system, valves should be in an open position to allow complete drainage.

♦ For detailed Operating Pressure, refer to Pressure Temperature Chart on page 107.

Class 150 Bronze Gate Valves

Block Pattern • Bolted Bonnet • Rising Stem • Solid Wedge

150 PSI/10.3 Bar Saturated Steam to 366° F/185° C
300 PSI/20.7 Bar Non-Shock Cold Working Pressure♦

CONFORMS TO MSS SP-80

MATERIAL LIST

PART	SPECIFICATION
1. Handwheel Nut	Zinc Plated Steel with Clear Chromate
2. Identification Plate	Aluminum
3. Handwheel	Aluminum Commercial Alloy 380
4. Stem	Silicon Bronze ASTM B 371 Alloy C69400
5. Packing Nut	Bronze ASTM B 62 or ASTM B 584 Alloy C84400 or Brass ASTM B 16
6. Packing Gland	Bronze ASTM B 62 or ASTM B 584 Alloy C84400 or Brass ASTM B 16
7. Packing	Aramid Fibres with Graphite
8. Bonnet	Bronze ASTM B 62
9. Bonnet Bolt	Zinc Plated Steel
10. Bonnet Gasket	Aramid Fibres with Graphite
11. Wedge	Bronze ASTM B 62
12. Body	Bronze ASTM B 62

DIMENSIONS—WEIGHTS—QUANTITIES

Size	Dimensions						T-134		S-134		Master Ctn. Qty	
	A		B		C		Lbs.	Kg.	Lbs.	Kg.		
In.	mm.	In.	mm.	In.	mm.	In.	mm.	Lbs.	Kg.	Lbs.	Kg.	
4	100	6.44	164	20.81	529	3.56	90	45.68	20.72	43.96	19.94	1

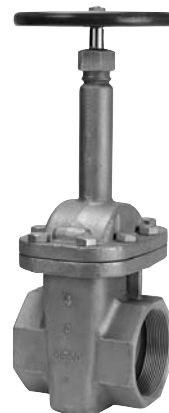

T-134
Threaded

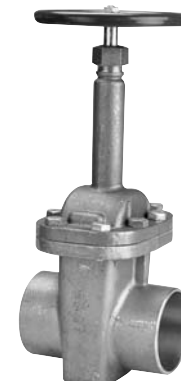

S-134
Solder

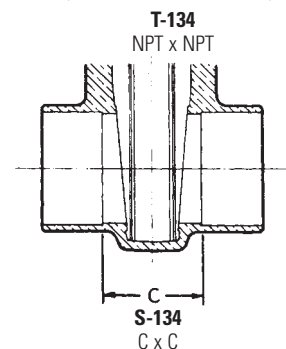
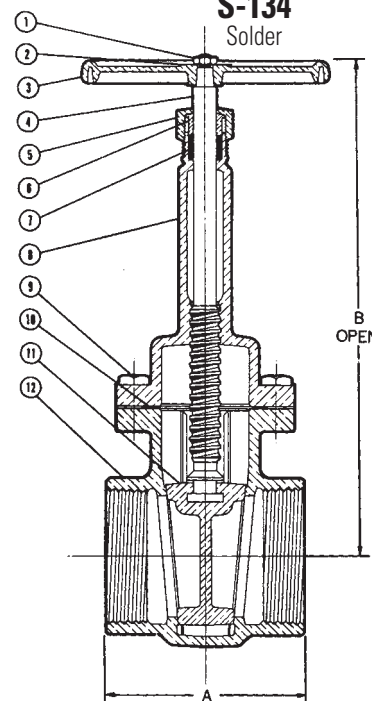

Freezing Weather Precaution – Subsequent to testing a piping system, valves should be in an open position to allow complete drainage.

♦ For detailed Operating Pressure, refer to Pressure Temperature Chart on page 107.

Class 150 Bronze Gate Valves

Block Pattern • Union Bonnet • Rising Stem • Split Wedge

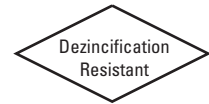

150 PSI/10.3 Bar Saturated Steam to 366° F/185° C
300 PSI/20.7 Bar Non-Shock Cold Working Pressure♦

CONFORMS TO MSS SP-80

MATERIAL LIST

PART	SPECIFICATION
1. Handwheel Nut	Zinc Plated Steel with Clear Chromate
2. Identification Plate	Aluminum
3. Handwheel	Malleable Iron ASTM A 47
4. Stem	Silicon Bronze ASTM B 371 Alloy C69400 or ASTM B 99 Alloy C65100
5. Packing Nut	Bronze ASTM B 62 or ASTM B 584 Alloy C84400 or Brass ASTM B 16
6. Packing Gland	Bronze ASTM B 62 or ASTM B 584 alloy C84400 or Brass ASTM B 16
7. Packing	Aramid Fibres with Graphite
8. Bonnet	Bronze ASTM B 62
9. Union Nut	Bronze ASTM B 62
10. Body	Bronze ASTM B 62
11. Wedge	Bronze ASTM B 62
12. Wedge Holder	Bronze ASTM B 62 (Not shown)



T-135
Threaded

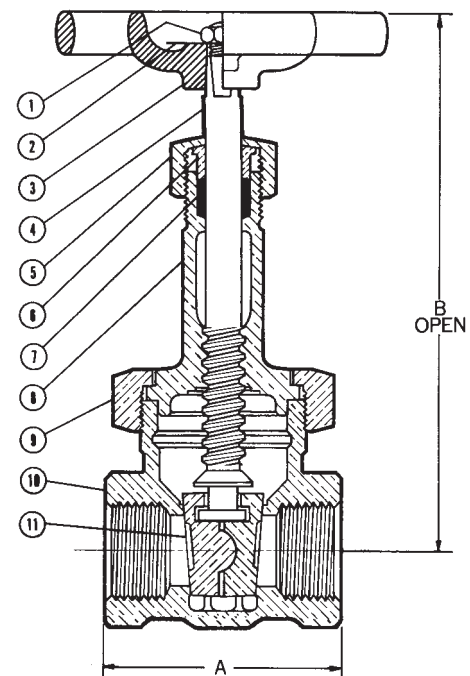

T-135
NPT x NPT

DIMENSIONS—WEIGHTS—QUANTITIES

Size	Dimensions				T-135		Master Ctn. Qty.	
	A		B		Lbs.	Kg.		
In.	mm.	In.	mm.	In.	mm.			
¼	8	1.88	48	4.81	122	1.09	0.50	50
⅜	10	2.06	52	4.81	122	1.13	0.51	50
½	15	2.31	59	5.38	137	1.42	0.64	40
¾	20	2.44	62	6.31	160	2.11	0.96	30
1	25	2.88	73	7.56	192	3.14	1.42	20
1¼	32	3.13	83	8.88	226	4.36	1.98	10
1½	40	3.34	86	10.25	260	5.97	2.71	10
2	50	3.88	99	12.50	318	9.85	4.47	6
2½	65	4.75	121	14.69	373	15.09	6.84	4
3	80	5.19	132	16.75	426	21.70	9.84	2

‡ Has wedge holder.

Freezing Weather Precaution – Subsequent to testing a piping system, valves should be in an open position to allow complete drainage.

♦ For detailed Operating Pressure, refer to Pressure Temperature Chart on page 107.

Class 150 Bronze Gate Valves

Block Pattern • Union Bonnet • Non-Rising Stem • Solid Wedge

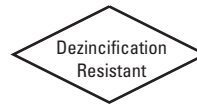

150 PSI/10.3 Bar Saturated Steam to 366° F/185° C
300 PSI/20.7 Bar Non-Shock Cold Working Pressure ♦

CONFORMS TO MSS SP-80

MATERIAL LIST

PART	SPECIFICATION
1. Handwheel Nut	Zinc Plated Steel with Clear Chromate
2. Identification Plate	Aluminum
3. Handwheel	Malleable Iron ASTM A 47
4. Stem	Silicon Bronze ASTM B 371 Alloy C69400 or ASTM B 99 Alloy C65100
5. Packing Nut	Bronze ASTM B 62 or ASTM B 584 Alloy C84400 or Brass ASTM B 16
6. Packing Gland	Bronze ASTM B 62 or ASTM B 584 Alloy C84400 or Brass ASTM B 16
7. Packing	Aramid Fibres with Graphite
8. Stuffing Box	Bronze ASTM B 62
9. Bonnet	Bronze ASTM B 62
10. Union Nut	Bronze ASTM B 62
11. Body	Bronze ASTM B 62
12. Wedge	Bronze ASTM B 62
13. Wedge Holder	Bronze ASTM B 62 (Not shown)



T-136
Threaded



S-136
Solder

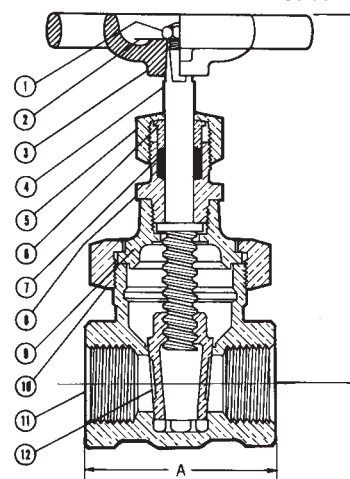

T-136
NPT x NPT

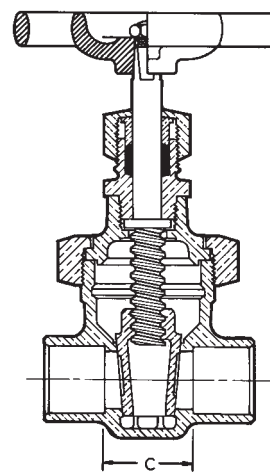

S-136
C x C

DIMENSIONS—WEIGHTS—QUANTITIES

Size	Dimensions						T-136		S-136		Master Ctn. Qty.	
	In.	mm.	A In.	mm.	B In.	mm.	In.	mm.	Lbs.	Kg.		Lbs.
¼	8	1.88	48	3.88	98	x	x	1.09	0.49	x	x	50
⅜	10	2.06	52	3.88	98	1.00	26	1.12	0.51	1.02	0.46	50
½	15	2.31	59	4.19	106	1.25	29	1.36	0.62	1.24	0.56	40
¾	20	2.44	62	4.63	117	1.19	30	2.03	0.92	1.90	0.86	30
1	25	2.88	73	5.44	138	1.38	35	2.97	1.35	2.82	1.28	20
1¼	32	3.13	83	6.06	154	1.50	38	4.23	1.92	3.95	1.79	10
1½	40	3.38	86	7.13	181	1.63	41	5.69	2.58	5.43	2.47	10
2	50	3.88	99	8.31	211	1.94	49	9.45	4.29	9.16	4.16	6
2½	65	4.75	121	9.50	241	1.31	59	14.49	6.57	13.74	6.24	4
3	80	5.19	132	10.44	265	2.50	64	20.68	9.38	18.84	8.55	2

‡ Split Wedge with wedge holder.
x Not available this size.

Freezing Weather Precaution – Subsequent to testing a piping system, valves should be in an open position to allow complete drainage.

♦ For detailed Operating Pressure, refer to Pressure Temperature Chart on page 107.

Class 150 Bronze Gate Valves

Block Pattern • Bolted Bonnet • Non-Rising Stem • Split Wedge

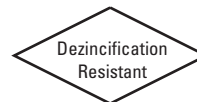

150 PSI/10.3 Bar Saturated Steam to 366° F/185° C
300 PSI/20.7 Bar Non-Shock Cold Working Pressure ♦

CONFORMS TO MSS SP-80

MATERIAL LIST

PART	SPECIFICATION
1. Handwheel Nut	Zinc Plated Steel with Clear Chromate
2. Identification Plate	Aluminum
3. Handwheel	Aluminum Commercial Alloy 380
4. Stem	Silicon Bronze ASTM B 371 Alloy C69400
5. Packing Nut	Bronze ASTM B 62 or ASTM B 584 Alloy C84400 or Brass ASTM B 16
6. Packing Gland	Bronze ASTM B 62 or ASTM B 584 Alloy C84400 or Brass ASTM B 16
7. Packing	Aramid Fibres with Graphite
8. Stuffing Box	Bronze ASTM B 62
9. Bonnet	Bronze ASTM B 62
10. Bonnet Bolt	Zinc Plated Steel
11. Bonnet Gasket	Aramid Fibres with Graphite
12. Body	Bronze ASTM B 62
13. Wedge	Bronze ASTM B 62
14. Wedge Holder	Bronze ASTM B 62



T-136
Threaded



S-136
Solder

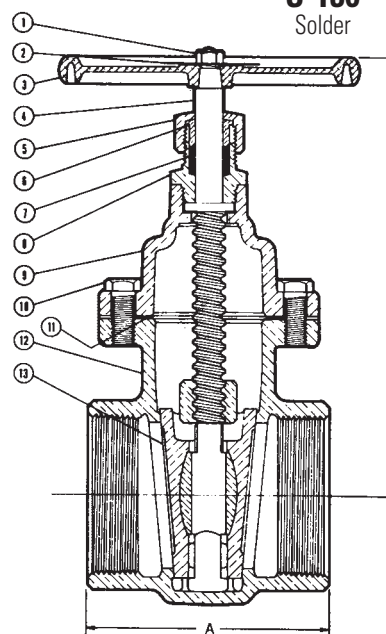

T-136
NPT x NPT

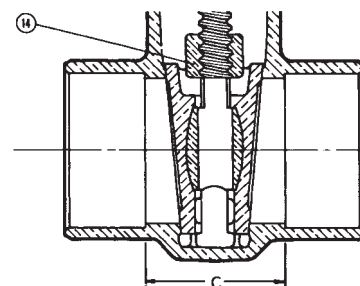

S-136
C x C

DIMENSIONS—WEIGHTS—QUANTITIES

Size	Dimensions						T-136		S-136		Master Ctn. Qty.	
	A		B		C		Lbs.	Kg.	Lbs.	Kg.		
In.	mm.	In.	mm.	In.	mm.	In.	mm.	Lbs.	Kg.	Lbs.	Kg.	
4	100	6.44	164	12.25	311	3.56	90	43.85	19.89	42.13	19.13	1

NOTE: Split wedge with wedge holder.

Freezing Weather Precaution – Subsequent to testing a piping system, valves should be in an open position to allow complete drainage.

♦ For detailed Operating Pressure, refer to Pressure Temperature Chart on page 107.

Class 200 Bronze Gate Valves

Block Pattern • Union Bonnet • Rising Stem • Alloy Solid Wedge

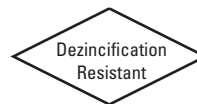

200 PSI/13.8 Bar Saturated Steam to 391° F/201° C
400 PSI/27.6 Bar Non-Shock Cold Working Pressure♦

CONFORMS TO MSS SP-80

MATERIAL LIST

PART	SPECIFICATION
1. Handwheel Nut	Zinc Plated Steel with Clear Chromate
2. Identification Plate	Aluminum
3. Handwheel	Malleable Iron ASTM A 47
4. Stem	Silicon Bronze ASTM B 371 Alloy C69400 or ASTM B 99 Alloy C65100
5. Packing Nut	Bronze ASTM B 62 or ASTM B 584 Alloy C84400 or Brass ASTM B 16
6. Packing Gland	Bronze ASTM B 62 or ASTM B 584 Alloy C84400 or Brass ASTM B 16
7. Packing	Aramid Fibres with Graphite
8. Bonnet	Bronze ASTM B 61
9. Union Nut	Bronze ASTM B 61
10. Body	Bronze ASTM B 61
11. Wedge	ASTM B 584 Alloy C97600



T-154-A
Threaded

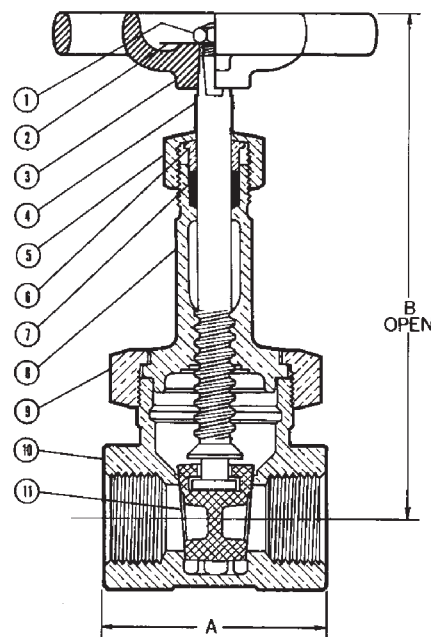

T-154-A
NPT x NPT
with Integral Seats

DIMENSIONS—WEIGHTS—QUANTITIES

Size	Dimensions				T-154-A		Master Ctn. Qty.
	in.	mm.	A in.	B in.	Lbs.	Kg.	
¼	8	1.88	48	4.81	122	1.15 0.52	50
⅜	10	2.06	52	4.81	122	1.14 0.52	50
½	15	2.31	59	5.38	137	1.49 0.68	40
¾	20	2.44	62	6.31	160	2.23 1.01	30
1	25	2.88	73	7.56	192	3.37 1.53	20
1 ¼	32	3.13	83	8.88	226	4.76 2.16	10
1 ½	40	3.38	86	10.25	260	6.32 2.87	10
2	50	3.88	99	12.50	318	10.96 4.97	6

Freezing Weather Precaution – Subsequent to testing a piping system, valves should be in an open position to allow complete drainage.

♦ For detailed Operating Pressure, refer to Pressure Temperature Chart on page 107.

Class 300 Bronze Gate Valves

Block Pattern • Union Bonnet • Rising Stem • Alloy Solid Wedge

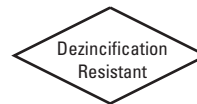

300 PSI/20.7 Bar Saturated Steam to 421° F/216° C
600 PSI/41.4 Bar Non-Shock Cold Working Pressure♦

CONFORMS TO MSS SP-80

MATERIAL LIST

PART	SPECIFICATION
1. Handwheel Nut	Zinc Plated Steel with Clear Chromate
2. Identification Plate	Aluminum
3. Handwheel	Malleable Iron ASTM A 47
4. Stem	Silicon Bronze ASTM B 371 Alloy C69400 or ASTM B 99 Alloy C65100
5. Packing Nut	Bronze ASTM B 62 or ASTM B 584 Alloy C84400 or Brass ASTM B 16
6. Packing Gland	Bronze ASTM B 62 or ASTM B 584 Alloy C84400 or Brass ASTM B 16
7. Packing	Aramid Fibres with Graphite
8. Bonnet	Bronze ASTM B 61
9. Union Nut	Bronze ASTM B 61
10. Body	Bronze ASTM B 61
11. Wedge	T-174-SS Bronze ASTM B 61 T-174-A ASTM B 584 Alloy C97600
12. Seats	T-174-SS Stainless Steel Type 410 ASTM A 276 Alloy 541000 T-174-A Integral with Body



T-174-SS
T-174-A
Threaded

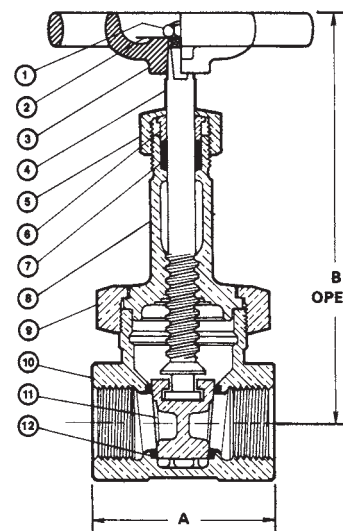

T-174-SS
NPT x NPT
with Stainless Steel Seats

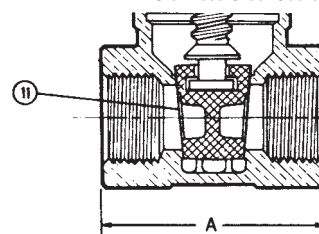

T-174-A
NPT x NPT
with Integral Seats

DIMENSIONS—WEIGHTS—QUANTITIES

Size	Dimensions										T-174-SS		T-174-A		Master Ctn. Qty.
	T-174-SS				T-174-A				Lbs.	Kg.	Lbs.	Kg.			
	A	B	A	B											
1/4	8	x	x	x	x	1.88	48	4.81	122	x	x	1.15	0.52	50	
3/8	10	x	x	x	x	2.06	53	4.81	122	x	x	1.14	0.52	50	
1/2	15	2.38	60	5.38	137	2.31	59	5.38	137	1.48	0.67	1.49	0.68	40	
3/4	20	2.69	68	6.31	160	2.44	62	6.31	160	2.23	1.01	2.23	1.01	30	
1	25	3.13	79	7.56	192	2.88	73	7.56	192	3.37	1.53	3.37	1.53	20	
1 1/4	32	3.44	87	8.88	226	3.13	79	8.75	222	4.74	2.15	4.76	2.16	10	
1 1/2	40	3.75	95	10.25	260	3.38	86	10.25	260	6.29	2.85	6.32	2.87	10	
2	50	4.25	108	12.50	318	3.88	99	12.50	318	10.84	4.92	10.96	4.97	6	

x Not available this size.

Freezing Weather Precaution – Subsequent to testing a piping system, valves should be in an open position to allow complete drainage.

♦ For detailed Operating Pressure, refer to Pressure Temperature Chart on page 107.

Class 300 Bronze Gate Valves

Block Pattern • Union Bonnet • Non-Rising Stem • Alloy Solid Wedge

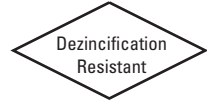

300 PSI/20.7 Bar Saturated Steam to 421° F/216° C
600 PSI/41.4 Bar Non-Shock Cold Working Pressure ♦

CONFORMS TO MSS SP-80

MATERIAL LIST

PART	SPECIFICATION
1. Handwheel Nut	Zinc Plated Steel with Clear Chromate
2. Identification Plate	Aluminum
3. Handwheel	Malleable Iron ASTM A 47
4. Stem	Silicon Bronze ASTM B 371 Alloy C69400 or ASTM B 99 Alloy C65100
5. Packing Nut	Bronze ASTM B 62 or ASTM B 584 Alloy C84400 or Brass ASTM B 16
6. Packing Gland	Bronze ASTM B 62 or ASTM B 584 Alloy C84400 or Brass ASTM B 16
7. Packing	Aramid Fibres with Graphite
8. Stuffing Box	Bronze ASTM B 61
9. Bonnet	Bronze ASTM B 61
10. Union Nut	Bronze ASTM B 61
11. Body	Bronze ASTM B 61
12. Wedge	T-176-SS Bronze ASTM B 61 T-176-A ASTM B 584 Alloy C97600
13. Seats	T-176-SS Stainless Steel Type 410 ASTM A 276 Alloy 541000 T-176-A Integral with Body

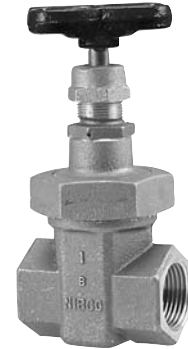

T-176-SS
T-176-A
Threaded

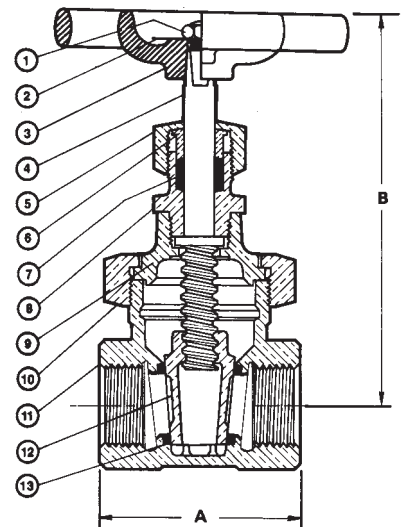

T-176-SS
NPT x NPT
with Stainless Steel Seats

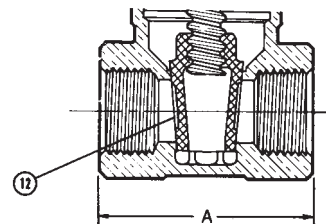

T-176-A
NPT x NPT
with Integral Seats

DIMENSIONS—WEIGHTS—QUANTITIES

Size	Dimensions										T-176-SS	T-176-A	Master				
	T-176-SS				T-176-A				Lbs.	Kg.				Lbs.	Kg.	Ctn.	Qty.
	A	B	A	B													
1/4	8	x	x	x	x	1.88	48	3.88	98	x	x	1.15	0.52	50			
3/8	10	x	x	x	x	2.06	53	3.88	98	x	x	1.14	0.52	50			
1/2	15	2.38	60	4.19	106	2.31	59	4.31	106	1.44	0.65	1.44	0.65	40			
3/4	20	2.69	68	4.63	117	2.44	62	4.63	117	2.15	0.98	2.13	0.97	30			
1	25	3.13	79	5.44	138	2.88	73	5.44	138	3.25	1.47	3.24	1.47	20			
1 1/4	32	3.44	87	6.06	154	3.13	79	6.06	154	4.56	2.07	4.57	2.07	10			
1 1/2	40	3.75	95	7.13	181	3.38	86	7.13	181	6.02	2.73	5.98	2.71	10			
2	50	4.25	108	8.31	211	3.88	99	8.31	211	10.46	4.74	10.18	4.62	6			

x Not available this size.

Freezing Weather Precaution – Subsequent to testing a piping system, valves should be in an open position to allow complete drainage.

♦ For detailed Operating Pressure, refer to Pressure Temperature Chart on page 107.