

Type 14 Flanged Diaphragm

Standard Features

- Flanged (ANSI) face-to-face dimensions are equivalent to most commonly used metallic valves
- Rugged body and bonnet are of solid thermo-plastic for maximum corrosion resistance
- Uniquely designed body and bonnet together with diaphragms of new sealing designs by computer dynamic analysis for superior sealing
- Weir design for excellent throttling
- Bubble-tight sealing, even in applications such as slurries or suspended particles
- Bonnet seals to protect internals from corrosive environments
- Built-in travel stop to prevent over-tightening or compressive strain on diaphragm
- Integrally molded bottom stand for simple yet firm panel mounting
- Indicator at the top for indication of valve position and prevention of over-tightening
- PVDF Gas Barrier, which protects EPDM backing from gas permeation, is standard for PVDF valves
- Low profile
- 1/2" - 2" in bayonet structure to connect compressor and diaphragm – easy diaphragm replacement

Options

- PVDF gas barrier for aggressive fluids
- 2" square nut
- "T" operating nut for remote operation
- Stem extensions (single and two-piece design)
- Locking device for tamper-proofing
- Manual limit switches for remote position indication by lights or for sequencing of other equipment
- Pneumatic (all sizes) or electric (to 3") actuation

Specifications

Sizes: 1/2" – 4"
Body Materials: PVC, CPVC, PP and PVDF
Bonnet Materials: PVC, PP, PPG and PVDF
Diaphragms: EPDM and PTFE
 Also available in other materials such as Nitrile, Butyl, Hypalon^{®†} and Neoprene^{®†}

† Trademarks of E. I. du Pont de Nemours and Company

Parts Type 14 Flanged (Sizes 1/2" – 2")

PARTS			
NO.	DESCRIPTION	PCS.	MATERIAL
1	Body	1	PVC, CPVC, PP, PVDF
2	Bonnet	1	PVC, PPG, PP, PVDF
3	Diaphragm	1	EPDM, PTFE, Others
3a	Diaphragm Metal Insert	1	Stainless Steel 304
4	Cushion*	1	EPDM
5	PVDF Gas Barrier*	1	PVDF
6	Compressor	1	PVDF
7	Joint	1	Stainless Steel 304
8	Stem	1	Copper Alloy
9	Sleeve	1	Copper Alloy
10	Hand Wheel	1	PP
11	Gauge Cover	1	PC
12	Name Plate	1	PVC
13	Retaining Ring C Type	1	Stainless Steel 304
14	O-Ring (A)	1	EPDM
15	O-Ring (B)	1	EPDM
16	Thrust Ring (A)	1	UHMEPE
17	Thrust Ring (B)	1	UHMEPE
18	Bolt, Nut, Washer	4 Sets	Stainless Steel 304
20	Stopper (A)	1	Copper Alloy
21	Screw	1	Stainless Steel 304

* Used on PTFE diaphragm



ASAHI/AMERICA

Rev. A 01-02

Type 14 Flanged

Diaphragm Valves

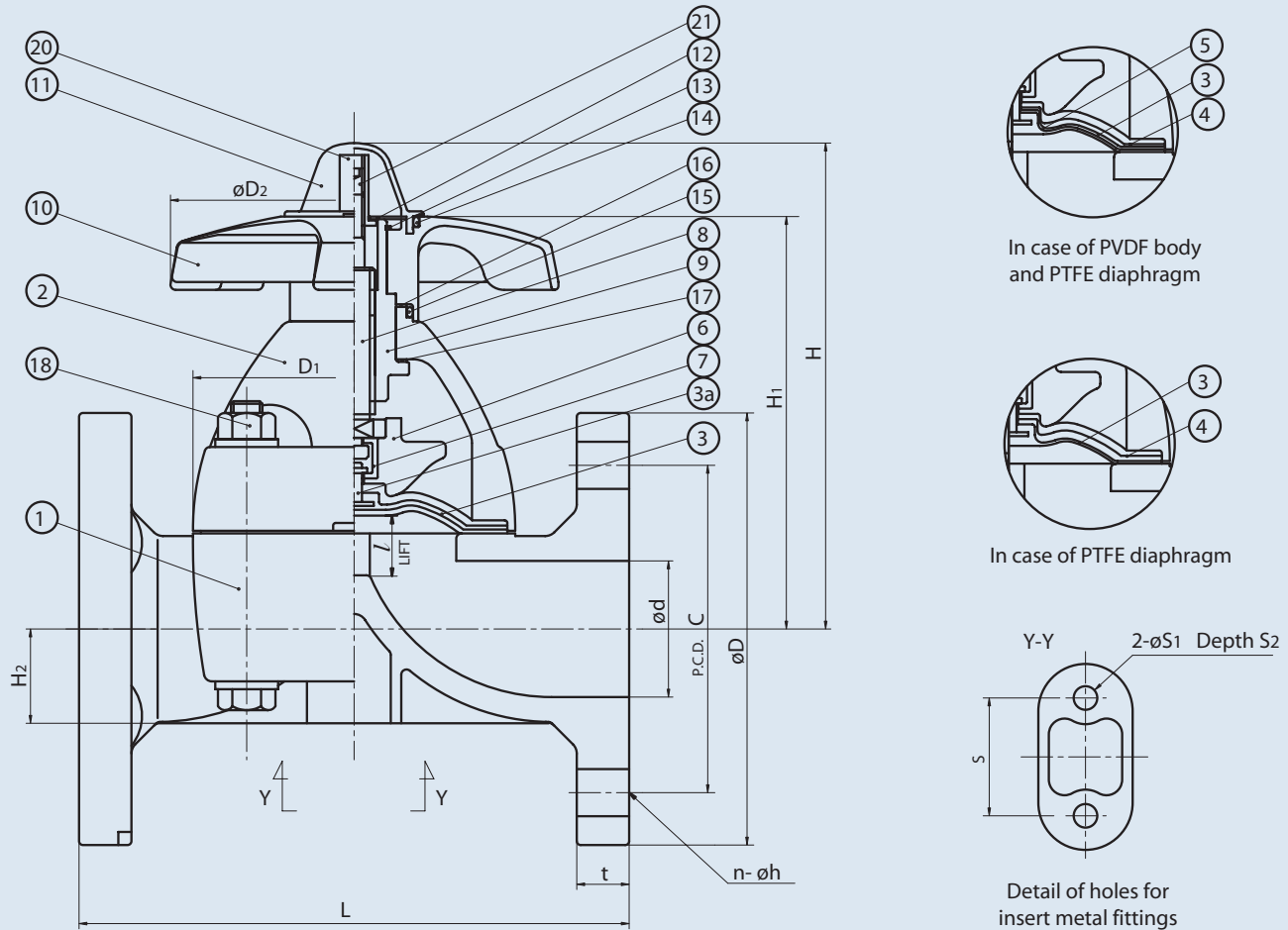

Dimensions Type 14 Flanged (Sizes 1/2" - 2")

NOMINAL SIZE		ANSI CLASS 150					D1	D2	l	L	t	H	H1	H2	S	S1	S2
INCHES	mm	d	C	D	n	h											
1/2	40	0.63	2.38	3.50	4	0.62	2.13 x 2.60	3.46	0.39	4.25	0.43	4.09	3.39	0.49	0.98	0.28	0.51
3/4	50	0.79	2.75	3.88	4	0.62	2.13 x 2.60	3.46	0.39	5.88	0.51	4.17	3.46	0.57	0.98	0.28	0.51
1	65	0.98	3.12	4.25	4	0.62	2.64 x 3.15	3.46	0.47	5.88	0.59	4.37	3.66	0.73	0.98	0.28	0.51
1 1/4	80	1.26	3.50	4.62	4	0.62	2.64 x 3.15	3.46	0.47	6.38	0.63	4.57	3.82	0.89	0.98	0.28	0.51
1 1/2	100	1.57	3.88	5.00	4	0.62	4.25 x 4.25	6.14	0.83	6.94	0.63	6.97	5.67	1.08	1.77	0.35	0.59
2	125	2.05	4.75	6.00	4	0.75	4.84 x 4.84	6.14	0.98	7.94	0.79	7.52	6.22	1.42	1.77	0.35	0.59

Pressure vs. Temperature PSI, WATER, NON-SHOCK

NOMINAL SIZE		PVC		CPVC				PP				PVDF			
		ALL DIAPHRAGMS		ALL DIAPHRAGMS				ALL DIAPHRAGMS				PTFE DIAPHRAGM			
INCHES	mm	30° F	106° F	30° F	106° F	141° F	176° F	-5° F	106° F	141° F	176° F	-40° F	141° F	176° F	211° F
		105° F	140° F	105° F	140° F	175° F	195° F	105° F	140° F	175° F	195° F	140° F	175° F	210° F	250° F
1/2	15	150	100	150	115	85	40	150	115	85	70	150	120	95	70
3/4	20	150	100	150	115	85	40	150	115	85	70	150	120	95	70
1	25	150	100	150	115	85	40	150	115	85	70	150	120	95	70
1 1/4	32	150	100	150	115	85	40	150	115	85	70	150	120	95	70
1 1/2	40	150	100	150	115	85	40	150	115	85	70	150	120	95	70
2	50	150	100	150	115	85	40	150	115	85	70	150	120	95	70

Cv Values/Wt.

NOMINAL SIZE		Cv	WT. FLG. (SOC.)
INCHES	mm		
1/2	15	4.8	1.50
3/4	20	5.3	1.80
1	25	8.5	2.40
1 1/4	32	11.0	3.10
1 1/2	40	26	6.20
2	50	43	8.00

Type 14 Flanged

Diaphragm Valves

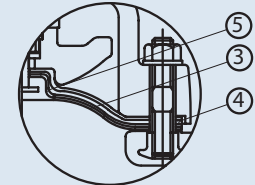
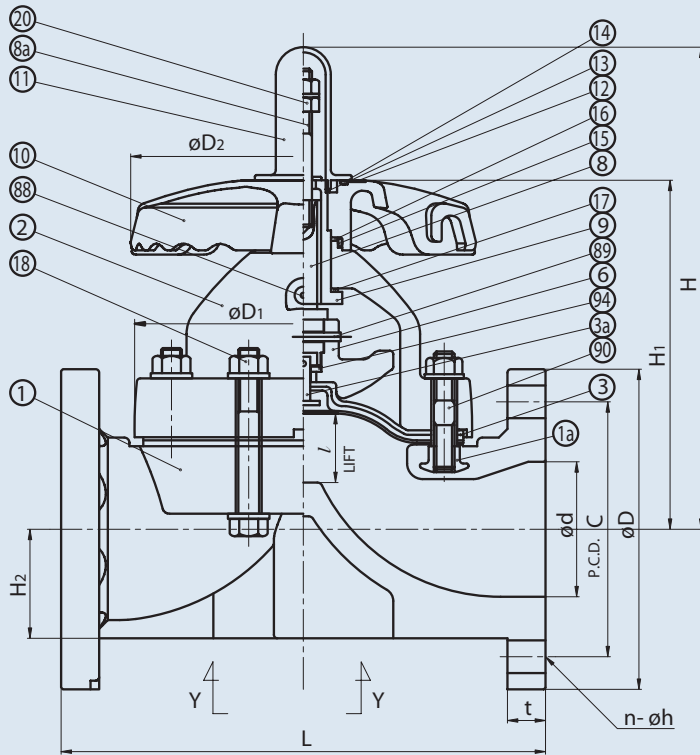

In case of PVDF body and PTFE diaphragm

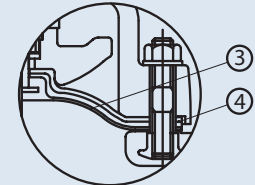

In case of PTFE diaphragm

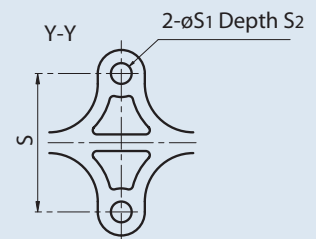

Detail of holes for insert metal fittings

Dimensions Type 14 Flanged (Sizes 2-1/2" - 4")

NOMINAL SIZE		ANSI CLASS 150										t		H	H ₁	H ₂	S	S ₁	S ₂
		d	C	D	n	h	D ₁	D ₂	l	L	PVC CPVC	PP PVDF							
INCHES	mm																		
2 1/2	65	2.64	5.50	7.00	4	0.75	6.89	8.66	1.34	9.84	0.87	0.91	10.47	7.40	2.40	3.35	0.43	0.79	
3	80	3.07	6.00	7.50	8	0.75	7.91	8.66	1.65	10.38	0.87	0.91	11.02	7.95	2.48	3.94	0.59	1.10	
4	100	3.94	7.50	9.00	8	0.75	9.49	10.12	1.97	12.94	0.87	0.94	12.95	9.49	3.07	4.72	0.59	1.10	

Pressure vs. Temperature PSI, WATER, NON-SHOCK

NOMINAL SIZE		PVC		CPVC				PP				PVDF			
		ALL DIAPHRAGMS		ALL DIAPHRAGMS				ALL DIAPHRAGMS				PTFE DIAPHRAGM			
		30° F 105° F	106° F 140° F	30° F 105° F	106° F 140° F	141° F 175° F	176° F 195° F	-5° F 105° F	106° F 140° F	141° F 175° F	176° F 195° F	-40° F 140° F	141° F 175° F	176° F 210° F	211° F 250° F
INCHES	mm														
2 1/2	65	150	115	150	120	95	85	150	120	95	85	150	115	85	70
3	80	150	115	150	120	95	85	150	120	95	85	150	115	85	70
4	100	150	115	150	120	95	85	150	120	95	85	150	115	85	70

Cv Values/Wt.

NOMINAL SIZE		Cv	WT. FLG. (LBS.)
INCHES	mm		
2 1/2	65	85	14.33
3	80	115	17.64
4	100	185	25.80

Caution

- After replacing diaphragm, do not tighten bolts for bonnet and body with diaphragm in the closed position. Excessive force could damage bonnet or body.
- Full vacuum rated 1/2" through 2 1/2"
- For vacuum service on 3" and 4", use our "Vacuum-Proof" type.
- Vacuum Rating

(1) Rubber Diaphragms	(2) PTFE Diaphragm
3" - 25.59"	- 9.84"
4" - 19.69"	- 3.94"
- Never remove valve from pipeline under pressure.
- Always wear protective gloves and goggles.

Type 14 Flanged

Diaphragm Valves

Parts Type 14 Flanged (2-1/2" – 4")

PARTS			
NO.	DESCRIPTION	PCS.	MATERIAL
1	Body	1	PVC, CPVC, PP, PVDF
2	Bonnet	1	PVC, PPG, PP, PVDF
3	Diaphragm	1	EPDM, PTFE, Others
3a	Diaphragm Metal Insert	1	Stainless Steel 304
4	Cushion*	1	EPDM
5	PVDF Gas Barrier*	1	PVDF
6	Compressor	1	PVDF
8	Stem	1	Copper Alloy
8a	Indicating Rod	1	Stainless Steel 304
9	Sleeve	1	Copper Alloy
10	Hand Wheel	1	PP
11	Gauge Cover	1	PC
12	Name Plate	1	PVC
13	Retaining Ring C Type	1	Stainless Steel 304
14	O-Ring (A)	1	EPDM
15	O-Ring (B)	1	EPDM
16	Thrust Ring (A)	1	UHMEPE
17	Thrust Ring (B)	1	UHMEPE
18	Bolt, Nut, Washer	4 Sets	Stainless Steel 304
20	Stopper (A)	1	Copper Alloy
88	Grease Nipple	1	Copper Alloy
89	Compressor Pin	1	Stainless Steel 304
90	Stud Bolt, Nut	4 Sets	Stainless Steel 304, Others
94	Metal of Compressor	1	Stainless Steel 304
1a	Inserted Nut	4	Stainless Steel 304 ¹ Copper Alloy ²

* Used on PTFE diaphragm

¹ Used for PVC body

² Used for PVC, CPVC, PP bodies

Troubleshooting

What if fluid leaks when valve is fully closed?

1. Travel stop not set correctly. Adjust it per the *Asahi Operation and Maintenance* manual.
2. Solids build up inside valve. Clean inside, including weir and diaphragm.
3. Diaphragm and/or weir are worn or damaged. Change the part(s).

What if valve cannot be fully opened?

1. Diaphragm is not properly engaged with compressor. Check engagement per *Operation and Maintenance* manual.

What if fluid leaks to atmosphere?

1. Bonnet bolts not properly torqued. Retorque according to *Operation and Maintenance* manual.
2. Line pressure exceeds maximum recommended line pressure. Check or reduce system line pressure.
3. Diaphragm has ruptured or has been chemically attacked. Replace diaphragm.

Sample Specification

All TYPE 14 flanged diaphragm valves shall be of solid thermoplastic construction for body and bonnet with molded flanged ends. The valves shall come standard with a position indicator, travel stop (to prevent over-tightening) and bonnet o-ring sealing arrangement. The valve shall be weir type with a square bonnet body sealing design and bayonet connection diaphragm (1/2" – 2") or round bonnet body sealing design and threaded stud diaphragm connection (2-1/2" – 4"). All PTFE diaphragms shall accept the installation of a PVDF gas barrier between the layers of EPDM and PTFE for aggressive chemical service. The face-to-face dimensions shall conform to TYPE G. PVC conforming to ASTM D1784 Cell Classification 12454-A, CPVC conforming to ASTM D1784 Cell Classification 23567-A, PP conforming to ASTM D4101 Cell Classification PPO210B67272, PPG (Bonnet Only) conforming to ASTM D4101 Cell Classification PPO110M20A21130, and PVDF conforming to ASTM D3222 Cell Classification Type II. PVC, CPVC, PP and PVDF shall be rated to 150 psi for elastomeric and PTFE diaphragms at 70 degrees F., as manufactured by Asahi/America, Inc.