

CPVC/PVC Butterfly Valves—Model-B

4" & 6" Body, Disk/Stem and Throttle Plate are PVC. 3" components are CPVC.

150 psi at 73°F water—non-shock (6" size 115 psi)



The Model-B is the best butterfly valve for chemical applications. The disk and stem sheath are molded over a 316 stainless hex shaft to make a one-piece assembly, making it impossible for the metal shaft to be exposed to the fluid medium over its full length of top and bottom stem. The upper and lower TFE bearing-bushings are vulcanized to the seat/boot as the boot is molded, making leakage between the boot and bushings impossible. The grooves for double O-ring seals are machined in the stem sheath of protective plastic for redundant stem leakage protection in conjunction with both the upper and lower bushings. Since these back-up stem seals rotate against the TFE bushings, valve shell leakage, indicating wear on the outside of these seals, is virtually unreported.

Features

- Mates between ANSI B 16.5, Class 150; ISO 2084 PN 10, DN 80; and DIN 2532, PN 10, DN 80. Both 4-bolt and 8-bolt patterns are in 3" size.
- Unique "dry shaft seal" – liquid never contacts shaft.
- Top bearing, as well as the upper and lower bushings, are glass-filled TFE for ease of operation and maximum service life.
- Seat/boot design eliminates need for gaskets between mating flanges.
- Selection of FPM or EPDM seat and seals offers resistance to diverse chemical/water applications. With FPM trim, valves have been notably successful in the disinfection services of chlorine and bleach injection.
- Valve accessories for manual operation in overhead or underground systems and other special needs are available. Refer to page 24.
- Refer to the *Chemtrol Valve Actuation Guide* for a full selection of electrical and pneumatic actuators with accessories. Mounting kits are available for field or factory assembly.

Notes

Installation and Maintenance Instructions for these valves appear on page 12. For more insight into the selection of materials, refer to *Materials*, page 1. *Actuation Mounting Data* for butterfly valves may be found on page 21, followed by a complete listing of *Valve Accessories*. For the specific relationships of pressure vs. temperature ratings, refer to *Engineering Data*, page 33. For *Chemtrol Valve Standards*, see page 35.

C_v Table

Size	Degrees Open								
	10°	20°	30°	40°	50°	60°	70°	80°	90°
3	4.3	16	35	62	94	135	180	235	290
4	8.6	34	76	137	215	310	420	550	690
6	17.5	67	200	265	410	580	790	1040	1340

Model-B Butterfly Valve Dimensions—Weights

Valve Size	A	B	C	D	E	J	G	H	R	Handle			Approx. ¹ Wt./Lbs.
										S	T	U	
3	4.75	1.26	7.00	3.06	8.50	2.00	3.62	3.38	.44	10.50	1.81	4.22	3.25
4	6.13	1.22	9.00	4.00	10.63	2.22	3.62	3.38	.56	10.50	1.81	4.22	6.00
6	7.50	1.62	11.00	5.97	13.00	2.77	3.76	3.50	.88	15.00	2.34	5.70	12.00

¹ Operator not included in weight.

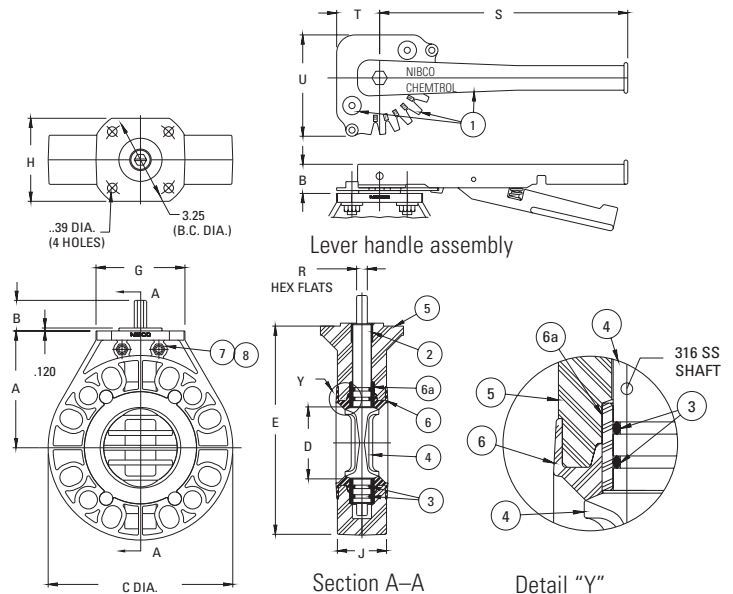

Chemtrol Figure Numbers

Seat Material	Operating Mechanism	3" (CPVC) ³	4" (PVC)	6" (PVC)
		Figure No.	Figure No.	Figure No.
EPDM	No Operator	W51BF-E-NO	W45BF-E-NO	W45BF-E-NO
	With Lever ² Handle	W51BF-E-LH	W45BF-E-LH	W45BF-E-LH
	With Gear Operator	NA	W45BF-E-GO	W45BF-E-GO
FPM ¹ (Viton)	No Operator	W51BF-V-NO	W45BF-V-NO	W45BF-V-NO
	With Lever ² Handle	W51BF-V-LH	W45BF-V-LH	W45BF-V-LH
	With Gear Operator	NA	W45BF-V-GO	W45BF-V-GO

¹ Fluoropolymer elastomer is also known as FKM. These seals are molded from Viton or Fluorel brands of rubber.

² Includes throttle plate and hardware.

³ Body and disk/stem for 3" size are available in CPVC only.

Construction

Part	Material
1. Lever Handle Assembly	Cast Iron w/ PVC ¹ Index Throttle Plate
2. Top Bearing	Glass-Filled TFE
3. O-Ring Seal (4 required)	FPM ² or EPDM
4. Disk/Stem	PVC ¹ w/ 316 Stainless Hex Shaft Insert-Molded
5. Body (2 required – mirror image)	3" - CPVC ¹ ; 4" & 6" - PVC
6. Seat/Boot	FPM ² or EPDM w/ GF-TFE Upper & Lower Bearing-Bushings Insert-Molded
7. Cap Screws; 3" Valve	(6) ea. 1/4"-20 x 7/8" Long Zinc Coated
4" Valve	(6) ea. 5/16"-18 x 1" Long Zinc Coated
6" Valve	(6) ea. 5/16"-18 x 1-1/2" Long & (2) ea. 5/16"-18 x 1" Long Zinc Coated
8. Hex Nuts; 3" Valve	(6) ea. 1/4"-20 Zinc Coated
4" Valve	(6) ea. 5/16"-18 Zinc Coated
6" Valve	(8) ea. 5/16"-18 Zinc Coated

¹ Body, disk/stem, and throttle plate for 3" size are available in CPVC only.

² FPM is also known as FKM. These seals are molded from Viton or Fluorel.

PVC Butterfly Valves—Model-C

150 psi at 73°F water—non-shock

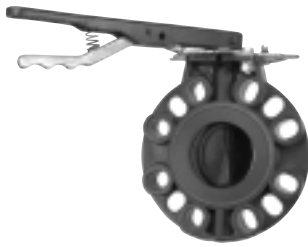

The Chemtrol Model-C Butterfly Valve is intended for general water applications. With National Sanitation Foundation (NSF) listing, it is ideal for potable water service. The Model-C valve has also been successfully used to handle mild acidic solutions and medium concentrations of alkaline solutions. However, this valve should not be used in water lines receiving chlorine gas or bleach injection. Nor should it be used in aquatic center recirculation lines, which receive low level bleach injection. Simple construction of the Model-C butterfly valve results from its unique design. It does not have a traditional rubber seat inside the bore of the one-piece molded body. Rather, EPDM is molded over a brass disk. This EPDM material is compressed between the brass portion of the disk and straight bore through the PVC body and creates the sealing mechanism for this butterfly valve. At assembly, two hardened 416 stainless steel shafts with splines on the inboard ends are swaged into the brass inner disk to become the upper and lower stems.

Features

- Glass-filled TFE bearing-bushings, extending almost the entire lengths of the upper and lower stems, transfer the hydraulic side load on the disk and evenly distributes it to the valve body to ensure low bearing stress with long, trouble-free operation.
- Rigid brass disk is encapsulated with EPDM.
- Durable one-piece molded PVC body.
- Built-in O-ring face-seals require no gaskets between mating flanges.
- Valve accessories for manual operation in overhead or underground systems and other special needs are available. Refer to page 24.
- Refer to the *Chemtrol Valve Actuation Guide* for a full selection of electrical and pneumatic actuators with accessories, including plastic housings. Mounting kits are available for field or factory assembly.

C_v Table

Size	Degrees Open								
	10°	20°	30°	40°	50°	60°	70°	80°	90°
2	2.5	8	18	33	50	73	100	131	166
2 1/2	3.7	12	27	49	74	109	148	195	247
3	4.3	16	35	62	94	135	180	235	290
4	8.6	34	76	137	215	310	420	550	690
6	17.5	67	200	265	410	580	790	1040	1340
8	20.8	83	190	320	530	770	1060	1380	1780
10	50.0	195	430	775	1200	1775	2700	3100	4000

Dimensions—Weights

Valve Size	A	B	C	D	E	F	G	H	I	J	K	L	Handle			Approx. ¹ Wt./Lbs.
													M	N	P	
2	1.94	1.69	6.41	1.25	3.94	3.29	3.25	2.75	0.44	3.26	0.37	0.50	10.50	1.01	6.19	2.02
2 1/2	2.44	1.81	7.19	1.25	4.13	3.63	3.25	2.75	0.44	3.26	0.37	0.50	10.50	1.01	6.19	2.56
3	2.87	1.81	7.75	1.15	4.43	3.91	3.25	2.75	0.44	3.26	0.37	0.50	10.50	1.01	6.19	2.92
4	3.82	2.06	9.08	1.25	5.31	4.57	3.25	2.75	0.44	3.26	0.50	0.65	10.50	1.01	6.19	5.04
6	5.76	2.20	11.22	1.25	7.09	5.64	3.25	2.75	0.44	3.26	0.56	0.78	13.75	1.01	6.19	8.99
8	7.74	2.36	13.66	1.25	8.00	6.83	3.25	2.75	0.44	3.26	0.56	0.78	13.75	1.01	6.19	14.27
10	9.57	2.68	16.49	1.25	9.84	8.40	5.00	4.01	0.56	4.76	0.74	1.06	Gear Operator Only			27.70

¹ Operator not included in weight.

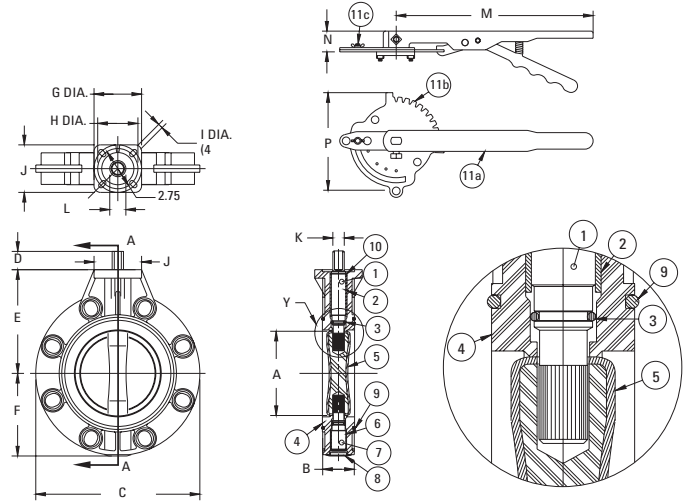

Notes

Installation and Maintenance Instructions for these valves appear on page 12. For more insight into the selection of materials, refer to *Materials*, page 1. *Actuation Mounting Data* for Butterfly Valves may be found on page 21, followed by a complete listing of *Valve Accessories*. For the specific relationships of pressure vs. temperature ratings, refer to *Engineering Data*, page 33. For *Chemtrol Valve Standards*, see page 35.

Construction

Part	Material
1. Upper Stem	416 Stainless Steel
2. Upper Bushing	Glass-Filled PTFE (Teflon)
3. O-Ring Stem Seal (2 required)	EPDM — Upper and Lower Stem
4. Body	PVC
5. Disk	EPDM Encapsulated Brass
6. Lower Bushing	Glass-Filled PTFE (Teflon)
7. Lower Stem	416 Stainless Steel
8. Plug	LDPE (Polyethylene)
9. O-Ring Face-Seal (2 required)	EPDM
10. Snap Ring (2 required)	Zinc Plated Steel
11. Lever Handle Assembly	
Handle w/Lever Lock	Malleable Iron
Throttling Plate	Zinc Plated Steel
Position Lock	Zinc Plated Steel

Chemtrol Figure Numbers

Disk Material	Operating Mechanism	2" – 10" Figure No. ¹
EPDM	Lever Handle ²	W45BG-E-3
	Gear Operator	W45BG-E-5

¹ 10" is available with gear operator only.

² Includes throttle plate and lock.

Installation and Maintenance Instructions

Model-B Butterfly Valves; 3"– 6" Model-C Butterfly Valves; 2"– 10"

Installation

Chemtrol Butterfly Valves are installed by bolting between two pipe flanges and may be mounted in any position. They are designed to be operated with pipes up to and including Schedule 80 wall thicknesses. If the I.D. of connecting pipe or equipment is smaller than Schedule 80, it will be necessary to chamfer the inside edge to avoid interference with the rotating butterfly disk. **Caution: Check for rotational clearance with pipe before proceeding. Do not install blind flanges directly to valve.**

Alignment—Excessive angular misalignment and/or axial displacement is detrimental to proper function of the companion flange face-seals built into the valves. For reference, ANSI/ASME B31.3, Code for Pressure Piping, Chemical Plant, and Petroleum Refinery Piping, stipulates that flange faces shall be aligned to the design plane (butterfly valve in this case) to within 1/16" in./ft. (0.5%) maximum measured across any diameter, and flange bolt holes shall be aligned to within 1/8" maximum offset.

Insertion in System—The end flaps of the elastomeric seat (Model-B) or the O-rings (Model-C) serve as face-seals for the companion flanges to be mounted on each side of the butterfly valve. Other gaskets are not to be used. Flange clearance required for insertion is given in the bolting chart below. For installation between the flanges, the valve should be partially open, but not so far as to damage the edge of the disk on mating flanges. If the spacing between mating flanges is tight, the valve sealing surface should be coated with a lubricant to prevent distortion during installation. If more than soapy water is required, a non-hydrocarbon base material, such as silicone grease, may be used on EPDM face-seals. An oil-based lubricant, such as glycerin, is acceptable for FPM face-seals. Insert valve in desired position and install bolts with metal back-up washers (*corresponding to ANSI B 18.22.1, designated N – narrow washers previously known as SAE series washers*) under both the bolt head and nut. Note: Bolt size x washer OD – 1/2", 1.092"; 5/8", 1.342"; 3/4", 1.499"; 7/8", 1.780".

Bolting—Snug up the bolts finger-tight so that the circumference of the inside bore of each companion flange evenly touches the face-seals of the butterfly valve. Make sure the valve is properly aligned before proceeding. Then, use of a torque wrench for pulling on the nuts is suggested for actual bolt tightening. It is critical that bolts be equally tightened in a sequential pattern diametrically opposed to each other, and that the final recommended bolt torque be accomplished through a minimum of three progressive stages of tightening. The recommended progressive tightening pattern and the final torque levels are shown on the following chart and diagram:

Valve Size (Nom.)	Flange Clearance Model B (in.)	Flange Clearance Model C (in.)	Bolt Diameter (in.)	Bolts Required (No.)	Recommended Bolt Torque ² (Ft.-Lbs.)
* 2	-	1.69	5/8	4	20-30
* 2 1/2	-	1.81	5/8	4	20-30
3	2.00	1.81	5/8	4 or 8 ¹	20-30
4	2.25	2.06	5/8	8	20-30
6	2.81	2.19	3/4	8	33-50
* 8	-	2.38	3/4	8	33-50
* 10	-	2.69	7/8	12	53-75

* Available in Model-C only.

¹ Four (4) bolt hole pattern for ANSI 150 flange pattern; eight (8) bolt hole pattern for DIN standard flange pattern.

² Refers to well-lubricated bolts.

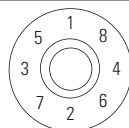

When valve installation is complete, open and close the valve to check for ease of operation and proper alignment. **Caution: Do not allow the valve to support the weight of any related piping. Direct support is required when mechanical operators or actuators are utilized.**

Maintenance

Given proper usage of Chemtrol Butterfly Valves, maintenance is minimal due to their design and materials of construction. Following testing and soon after commissioning of a system, if either the Model-B or Model-C valve develops a leak at the top bearing, the flange face-seal(s), and/or across the valve disk, the most likely suspicion would be inappropriate selection of the elastomeric seat and seals. In this case, check the *Chemtrol Chemical Resistance Guide* for compatibility with the fluid medium. If there is leakage at the flange face-seal(s) only, further tightening of bolts will almost never stop any flange joint leak. Rather, the remedy is to disassemble the joint and reseat the flanges on the valve face-seals, being careful to follow the *Bolting* paragraph under the *Installation* section of this instruction page.

After extended operation, if leakage should occur at the top bearing or across the valve disk of either the Model-B or Model-C valve, this is an indication of wear to the elastomeric seat and/or O-ring seals, requiring their replacement. In most cases, valve replacement will be found less expensive than parts replacement. In fact, the Model-C valve cannot be disassembled. Only the handle assembly and O-ring face-seals may be replaced. Otherwise, replacement of the entire Model-C valve is recommended. When maintenance to a Model-B valve is required, the following procedure is recommended:

Disassembly of Valve—Model B only

- Remove top-works from valve.
 - Handle assembly is removed by loosening bolt and pulling upward. Remove the two hold-down bolts and lift index plate from valve.
 - Gear operator is removed by unscrewing hex head screws which hold operator to valve body.
 - Actuator mounting bracket on automated valves is removed by unscrewing hex head screws which hold bracket to valve body.
- The body halves are then separated by removing cap screws and hex nuts. Valve should be clamped in a vise by the hexagonal metal shaft and the body halves pried apart at opposite end with a small screwdriver or similar thin edged metal tool. The end flaps of the elastomeric seat should be flexed downward toward the valve I.D. as the body halves are being separated.
- After removal of body halves, the elastomeric seat can be removed from the disk/shaft manually by stretching the bottom of the seat over the lower end of the stem. Unclamp the shaft from the vise and slide off the top bearing. Then, slide the seat free of the upper end of the stem.

Inspect all parts for wear and replace as necessary. If the valve has been leaking, it is suggested that the seat and the O-ring seals be replaced.

Assembly of Valve

- Lubricate the O-rings and slide them into O-ring grooves on the stem. Then, lubricate the stem and slide top of the elastomeric seat over the top (long end) of stem and push down over the O-rings. Next, stretch the opposing end of the seat over the remaining (short) end of the stem. Care must be taken to assure that the O-rings remain in place during the assembly. A lubricant (such as Dow Corning No. 7 Silicone Grease) should be used to aid the assembly. Do not use Vaseline or other petroleum-based products on EPDM seats.
- Slide the top bearing on the stem. Take one body half and, starting at the bottom of the valve, work the end flap of the elastomeric seat into the opening of the body. Carefully press the body into position on the seat. Repeat procedure with other body half and bolt together following the procedure noted above.
- Reassemble top-works, install valve, and pressure test. In reassembly of lever handle, align the index plate so that the number one (1), indicating the full closed* position, is at right angles to the bore of the valve.

* With top-works removed from valve, a slot on top of the metal shaft in the disk/stem indicates the disk position.

Note: Refer to pages 10 & 11 for sectional views of the valves and complete construction lists.