

Swing Check Valve

Standard Features (Sizes 3/4" – 8")

- Minimum flow resistance - Low pressure drop
- Horizontal or vertical installation
- All sizes rated for full vacuum service
- Minimum back pressure to seat disc tightly
- Top access cover facilitates maintenance without body removal from pipeline
- All thermoplastic body
- All PVC parts made of high impact PVC
- PVC and PP Valves come with EPDM seals (Part #'s 5j, 5k, 6 and 7) as standard
- PVDF Valves, Part #'s 5j and 7 of PTFE and 6 of PVDF bonded EPDM

Options:

- External lever and weight to assist disc in closing faster
- External spring to assist disc in closing faster
- PTFE or Viton® seals



Specifications

- Sizes:** 3/4" – 8"
Models: Flanged (ANSI) Connection Only
 Lever and Weight Option
Bodies: PVC, PP and PVDF
Seats: EPDM, Viton®†, PTFE

† Trade mark of E. I. du Pont de Nemours and Company

Parts List (Sizes 3/4" – 8")

PARTS			
NO.	DESCRIPTION	PCS.	MATERIAL
1	Body	1	PVC, PP, PVDF
2	Bonnet	1	PVC, PP, PVDF
3	Shaft	1	PVC, PP, PVDF
4	Plug	1	PVC, PP, PVDF
5a	Disc	1	PVC, PP, PVDF
5b	Seat Holder	1	PVC, PP, PVDF
5c	Bolt (A)	-	PVC, PP, PVDF
5d	Arm	1	PVC, PP, PVDF
5e	Washer	1	PVC, PP, PVDF
5f	Nut (A)	1	PVC, PP, PVDF
5g	Pin	1	PVC, PP, PVDF
5h	Bolt (B)	1	PVC, PP, PVDF
5i	Nut (B)	1	PVC, PP, PVDF
5j	Seat	1	EPDM, PTFE, Others
5k	O-Ring	1	EPDM, PTFE, Others
6	Gasket (A)	1	EPDM, PTFE, Others
7	Gasket (B)	1	EPDM, PTFE, Others
8	Bolt, Nut, Washer	Set	Stainless Steel 304
1a	Ring	-	Stainless Steel 304

Parts List (Lever and Weight)

PARTS			
NO.	DESCRIPTION	PCS.	MATERIAL
1	Fitting	1	PVC, PP, PVDF
2	Nut	1	PVC, PP, PVDF
3	Shaft	1	Stainless Steel 316
4	Counter Weight	1	PVC
5	Spacer	1	PVC, PP, PVDF
6	O-Ring	1	EPDM, Viton®
7	Hex Cap Bolt	Set	Stainless Steel 300
8	Set Screw	Set	Stainless Steel 300
9	Sleeve	1	Stainless Steel 300

Swing Check Valve

STANDARD MODEL 3/4"

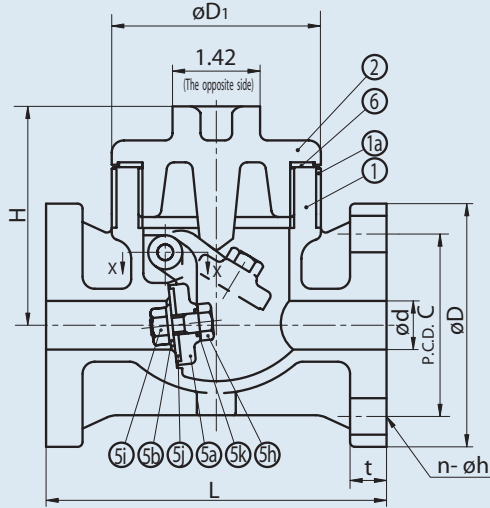

1"–8"

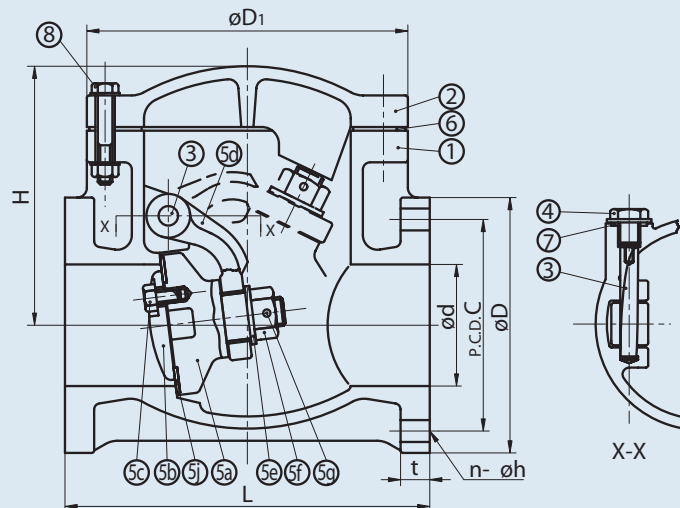

LEVER AND WEIGHT OPTION

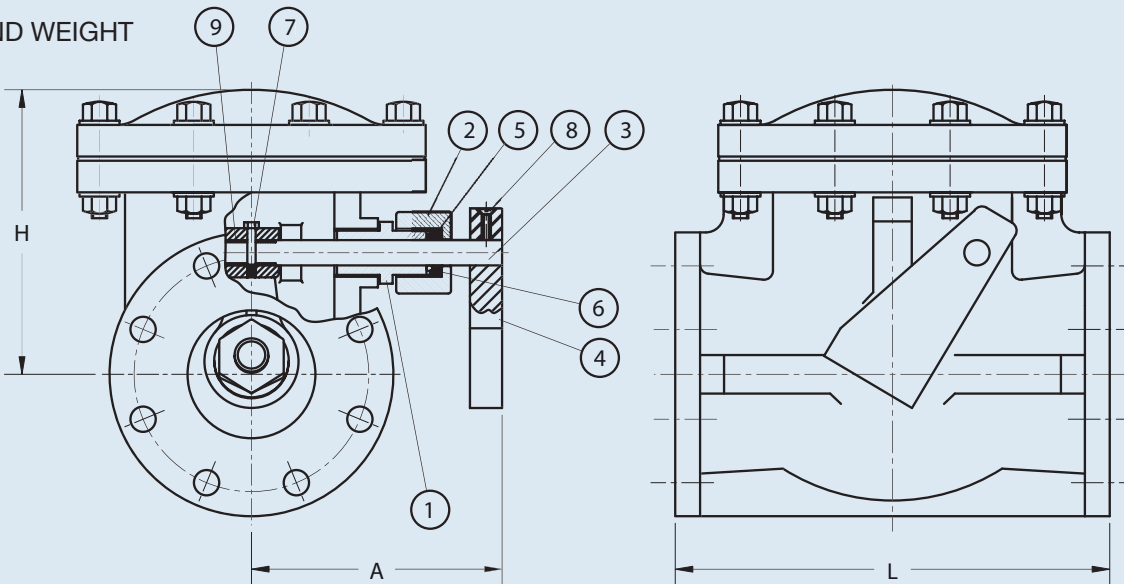

Dimensions (Sizes 3/4" – 8")

NOMINAL SIZE		d	ANSI CLASS 150				D1	L	T		H
INCHES	mm		C	D	h	n			PVC	PP, PVDF	
3/4	20	0.79	2.75	3.88	0.62	4	3.39	5.51	0.59	0.59	3.54
1	25	0.98	3.12	4.25	0.62	4	5.12	6.30	0.63	0.63	4.72
1 1/2	40	1.57	3.88	5.00	0.62	4	5.71	7.09	0.71	0.71	5.43
2	50	1.97	4.75	6.00	0.75	4	7.09	7.87	0.79	0.83	6.46
2 1/2	65	2.56	5.50	7.00	0.75	4	7.87	9.45	0.87	0.91	6.61
3	80	3.15	6.00	7.50	0.75	4	8.07	10.24	0.87	0.98	6.73
4	100	3.94	7.50	9.00	0.75	8	10.43	11.81	0.94	1.02	8.39
5	125	4.92	8.50	10.00	0.88	8	12.99	13.78	0.94	1.06	9.76
6	150	5.91	9.50	11.00	0.88	8	14.57	15.75	0.98	1.06	11.14
8	200	7.87	11.75	13.50	0.88	8	16.73	19.69	1.18	1.34	13.23

Dimensions (Lever & Weight/External Spring)

NOMINAL SIZE		A	H
INCHES	mm		
3/4	20	4.0	3.54
1	25	4.5	4.72
1 1/2	40	5.0	5.43
2	50	5.5	6.46
2 1/2	65	6.0	6.61
3	80	6.5	6.73
4	100	8.0	8.39
5	125	10.0	9.76
6	150	10.5	11.14
8	200	12.0	13.23

Swing Check Valves

Pressure vs. Temperature (PSI, WATER, NON-SHOCK)

NOMINAL SIZE		PVC		PP				PVDF		
		ELASTOMERS	PTFE	ELASTOMERS		PTFE		PTFE		
		30° F 120° F	30° F 120° F	-5° F 140° F	141° F 175° F	-5° F 140° F	141° F 175° F	-30° F 140° F	141° F 175° F	176° F 210° F
INCHES	mm									
3/4	20	100	85	100	85	90	75	90	75	60
1	25	100	85	100	85	90	75	90	75	60
1 1/2	40	100	85	100	85	90	75	90	75	60
2	50	100	85	100	85	90	75	90	75	60
2 1/2	65	100	85	100	85	90	75	90	75	60
3	80	75	75	75	85	75	60	75	60	45
4	100	75	75	75	60	75	60	75	60	45
5	125	75	60	75	60	60	45	60	45	40
6	150	75	45	75	60	45	30	45	40	30
8	200	45	45	45	30	45	30	45	40	30

Troubleshooting

What if valve leaks through the seat?

1. Sediment build-up around disc and seat. Clean disc and seat.
2. Disc or seat broken or damaged. Replace disc or seat.
3. Insufficient back pressure. Check the pressure.

What if valve leaks between bonnet and body?

1. Bolts not tightened properly. Tighten firmly per specified torque.
2. Seal chemically attacked or worn. Replace seal.
3. Exceeds maximum allowable pressure rating

Minimum Back Pressure to Close Valve (PSI)

NOMINAL SIZE		SEAT	
INCHES	mm	EPDM	PTFE
3/4	20	2.8	5.0
1	25	5.0	8.5
1 1/2	40	5.0	8.5
2	50	5.0	8.5
2 1/2	65	5.0	8.5
3	80	5.7	8.5
4	100	5.7	9.2
5	125	5.7	9.2
6	150	6.4	10.0
8	200	6.4	10.0

Cv Values

NOMINAL SIZE		Cv
INCHES	mm	
3/4	20	14
1	25	24
1 1/2	40	81
2	50	140
2 1/2	65	250
3	80	280
4	100	510
5	125	750
6	150	1100
8	200	1900

Sample Specification

All Swing Check valves shall be of solid thermo-plastic construction, having no metal that comes in contact with media. Valves shall incorporate a single disc design suitable for either horizontal or vertical installations. Valves shall be of top entry bonnet design for maintenance purposes. PVC shall conform to ASTM D1784 Cell Classification 12454-A, PP conforming to ASTM D4101 Cell Classification PP0210B67272 and PVDF conforming to ASTM D3222 Cell Classification Type II Valves shall be rated to 100 psi sizes 3/4" thru 3", 75 psi sizes 4" thru 6", 45 psi size 8" for PVC or PP with EPDM or Viton® seals, 85 psi sizes 3/4" thru 2-1/2", 75 psi sizes 3" & 4", 60 psi size 5" and 45 psi sizes 6" & 8" for PVC with PTFE seals, 90 psi sizes 3/4" thru 2 1/2", 75 psi sizes 3" & 4", 60 psi size 5" and 45 psi sizes 6" & 8" for PP or PVDF with PTFE seals all at 70 degrees F, as manufactured by Asahi/America, Inc.

Weight

NOMINAL SIZE		LBS.
INCHES	mm	
3/4	20	2.20
1	25	4.40
1 1/2	40	6.61
2	50	10.14
2 1/2	65	14.33
3	80	16.53
4	100	26.45
5	125	44.00
6	150	59.52
8	200	92.59