

## ANSI CLASS 300 CAST STEEL SWING CHECK VALVE

**FIG. 278-CS-300** Class 300, Flanged ends, bolted cover, WCB body & cover, 13Cr/HF trim.



Flange dimensions: ANSI B16.5  
 Face-to-Face dimensions: ANSI B16.10  
 Testing: API 598  
 Design: API 600

### Materials:

No.	Part Name	Specification
1	Body	A216 WCB
2	Cover	A216 WCB
3	Disc	A216 WCB + 13Cr overlay
4	Hinge	A216 WCB
5	Hinge pin	A276 – 410
6	Nameplate	304SS
7	Set screw	A276 – 410
8	Hook screw	Carbon steel
9	Disc nut	A276 – 410
10	Gasket	304 Wound Grafoil
11	Stud/nut	B7/2H
12	Seat ring	A105 + HF

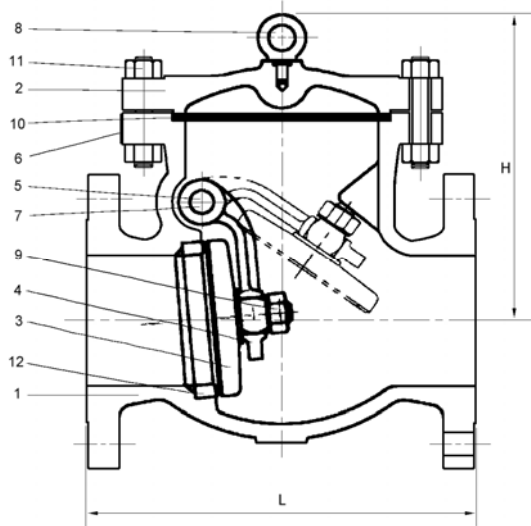

**Note:** Standard valve has a welded seat ring.

**Note:** Other body & trim materials are available upon request.

### Dimensions:

Size		L		H		Weight	
in	mm	in	mm	in	mm	lb	kg
2	50	10½	267	7	180	66	30
2½	65	11½	292	7¼	185	90	41
3	80	12½	318	8¼	210	110	50
4	100	14	356	10⅝	270	161	73
5	125	15¼	400	13½	345	200	91
6	150	17½	444	14¼	360	330	150
8	200	21	533	14½	370	510	232
10	250	24½	622	15⅝	385	774	352
12	300	28	711	17¼	440	1151	523
14	350	33	838	20½	520	1500	682
16	400	34	864	21¼	554	1850	841
18	450	38½	978	23¼	590	2255	1025
20	500	40	1016	24¼	614	2904	1320
24	600	53	1346	28	710	4314	1961
30	750	62¼	1594	34	865	7194	3270