

ANSI CLASS 600 CAST STEEL SWING CHECK VALVE

FIG. 278-CS-600 Class 600, Flanged ends, bolted cover, WCB body & cover, 13Cr/HF trim.

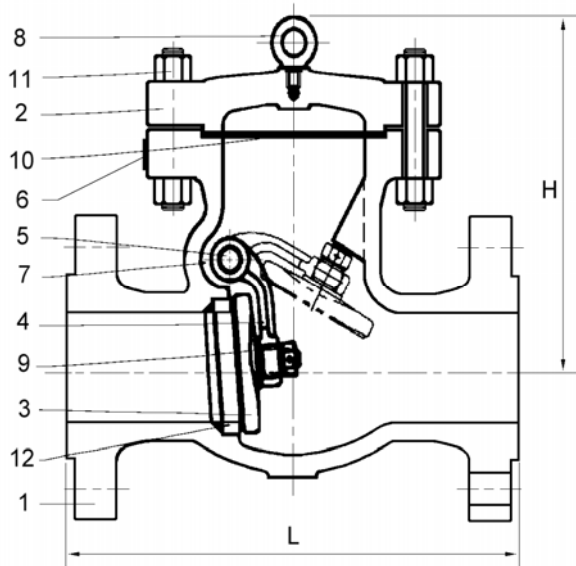

Flange dimensions: ANSI B16.5
 Face-to-Face dimensions: ANSI B16.10
 Testing: API 598
 Design: API 600

Materials:

No.	Part Name	Specification
1	Body	A216 WCB
2	Cover	A216 WCB
3	Disc	A216 WCB + 13Cr overlay
4	Hinge	A216 WCB
5	Hinge pin	A276 – 410
6	Nameplate	304SS
7	Set screw	A276 – 410
8	Hook screw	Carbon steel
9	Disc nut	A276 – 410
10	Gasket	304 Wound Grafoil
11	Stud/nut	B7/2H
12	Seat ring	A105 + HF

Note: Standard valve has a welded seat ring.

Note: Other body materials & trims are available upon request.

Dimensions:

Size		L		H		Weight	
in	mm	in	mm	in	mm	lb	kg
2	50	11.5	292	7.75	197	77	35
2½	65	13	330	8.13	207	100	45
3	80	14	356	9.13	231	140	64
4	100	17	432	11	281	255	116
6	150	22	559	14.25	362	460	209
8	200	26	660	17.25	437	860	391
10	250	31	787	19.25	490	1290	586
12	300	33	838	20.75	528	1730	786
14	350	35	889	22.5	572	2080	945
16	400	39	991	26	660	2685	1220
18	450	43	1092	28.5	720	3565	1620
20	500	47	1194	29.5	746	4665	2120
24	600	55	1397	37.75	960	6820	3100