

ANSI CLASS 150 CAST STEEL SWING CHECK VALVE

FIG. 278-CS-150 Class 150, Flanged ends, bolted cover, WCB body & cover, 13Cr/HF trim.



Flange dimensions: ANSI B16.5
 Face-to-Face dimensions: ANSI B16.10
 Testing: API 598
 Design: API 600

Materials:

No.	Part Name	Specification
1	Body	A216 WCB
2	Seat ring	105 + HF
3	Disc	A216 WCB + 13Cr overlay
4	Disc nut	A276 – 410SS
5	Hinge	A216 WCB
6	Hinge pin	A276 – 410SS
7	Cover	A216 WCB
8	Stud	B7
9	Nut	2H
10	Gasket	304SS Wound Grafoil
11	Washer	Carbon steel

Note: Standard valve has a welded seat ring.

Note: Other body & trim materials are available upon request.

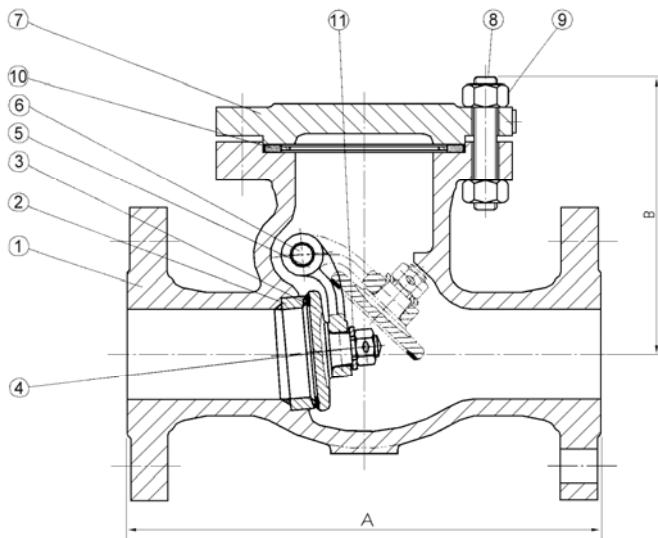

Dimensions:

Size		L		H		Weight	
in	mm	in	mm	in	mm	lb	kg
2	50	8	203	5.88	150	40	18
2½	65	8.5	216	6.63	168	50	23
3	80	9.5	241	7	180	68	31
4	100	11.5	292	8.25	210	102	46
5	125	13	330	9	230	133	60
6	150	14	356	10.25	275	180	82
8	200	19.5	495	13.5	340	305	139
10	250	24.5	622	14	355	455	207
12	300	27.5	698	16.13	410	675	307
14	350	31	787	18.75	475	875	398
16	400	34	864	21.75	552	1300	591
18	450	38.5	978	23.5	600	1450	659
20	500	38.5	978	26	660	1980	900
24	600	51	1295	29.13	740	2500	1136
30	750	60	1524	40.75	1035	4660	2118