

CLASS 800 FORGED STEEL BOLTED BONNET GATE VALVE

FIG. FGA-801T



Design: API 602
 Testing: API 598
 Threaded ends to: ASME B1.20.1
 Socket weld ends to: ASME B16.11

Materials:

No.	Part Name	Specification
1	Body	ASTM A105
2	Wedge	ASTM A276 420
3	Seat ring	ASTM A276 410
4	Stem	ASTM A276 410
5	Gasket	Graphite/304SS
6	Bonnet	ASTM A105
7	Bonnet bolt	ASTM A193 B7
8	Stem packing	Graphite
9	Gland	ASTM A276 410
10	Gland flange	ASTM A105
11	Gland eyebolt	ASTM A193 B7
12	Gland nut	ASTM A194 2H
13	Stem nut	ASTM A194 2H
14	Handwheel	A197

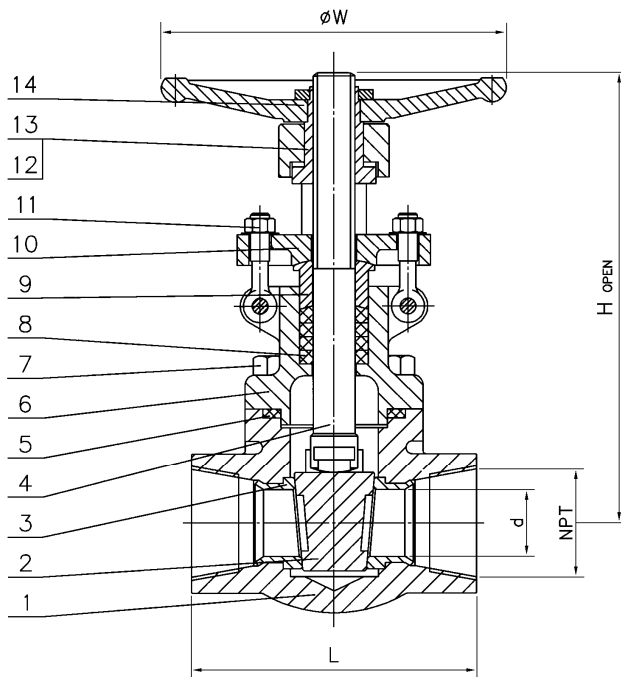

Rating:

Carbon Steel class 800 – 1975 psig @ 100°F

Note:

- The above figure number (FGA-801T) designates threaded valve. If a socket weld end is required, change the "T" to an "S" (FGA-801S).
- Other trims and body materials are available upon request.
- Rolled in seat ring.
- Regular port.

Dimensions:

Size		d		L		H		W		Weight	
in	mm	In	mm	In	mm	in	mm	in	mm	lb	kg
½	15	.39	10	3.11	79	6.65	169	3.94	100	4.6	2.1
¾	20	.54	13.6	3.62	92	7.17	182	3.94	100	5.0	2.3
1	25	.71	18	4.37	111	8.19	208	4.92	125	8.8	4.0
1¼	32	.94	24	4.72	120	9.25	235	6.30	160	13	5.9
1½	40	1.14	29	4.72	120	11.42	290	6.30	160	15.2	6.9
2	50	1.45	36.8	5.51	140	12.99	330	7.09	180	24.7	11.2