

CLASS 800 FORGED STEEL BOLTED BONNET GLOBE VALVE

FIG: FGL-820T

Design: API 602
 Testing: API 598
 Threaded ends to: ASME B1.20.1
 Socket weld ends to: ASME B16.11

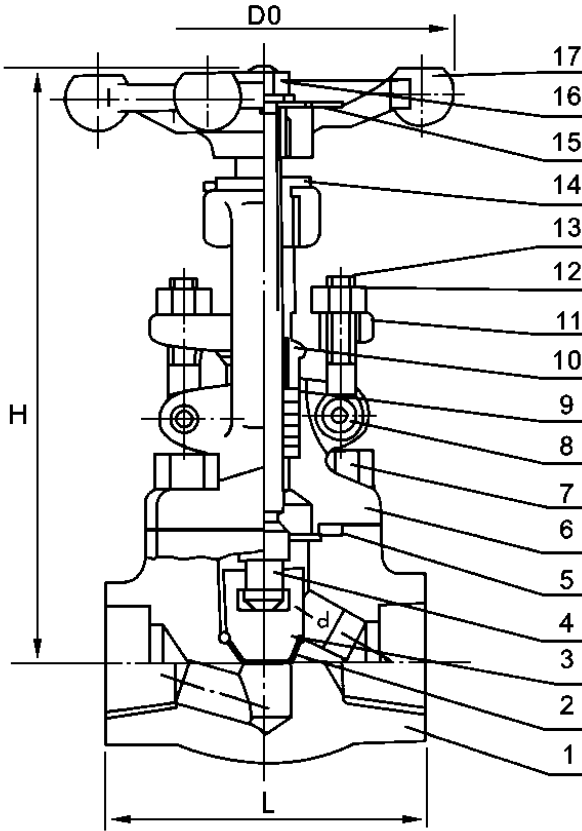

Materials:

No.	Part Name	Specification
1	Body	A105
2	Seat	Stellite overlay
3	Disc	A276-420
4	Stem	A276-410
5	Gasket (spiral wound)	304SS/Graphite
6	Bonnet	A105
7	Bolt	A193-B7
8	Eyebolt pin	A276 – 410
9	Packing	Grafoil
10	Gland	A276-410
11	Gland flange	A105
12	Eyebolt nut	A194-2H
13	Eyebolt	A276-410
14	Stem nut	A276-410
15	Washer	A276-430
16	Lock nut	A108-1020
17	Handwheel	A47

Rating:

Carbon Steel class 800 – 1975 psig @ 100°F

Note:

- The above figure number (FGL-820T) designates threaded valve. If a socket weld end is required, change the "T" to an "S" (FGL-820S).
- Other trims and body materials are available upon request.
- Both bolted bonnet and welded bonnet have the same dimensions.
- Integral HF seat.
- Regular port.

Dimensions:

Size		d		L		H (Open)		Do		Weight	
in	mm	In	mm	In	mm	in	mm	in	mm	lb	kg
½	15	.39	10	3.11	79	6.57	167	3.94	100	4.85	2.2
¾	20	.51	13	3.62	92	6.57	167	3.94	100	5.07	2.3
1	25	.69	17.5	4.37	111	8.03	204	4.92	125	9.30	4.2
1¼	32	.91	23	4.72	120	8.98	228	6.30	160	13.69	6.2
1½	40	1.18	30	5.98	152	9.92	252	6.30	160	17.20	7.8
2	50	1.38	35	6.77	172	11.61	295	7.09	180	27.12	12.3