

---

**CLASS 150/300 FLANGED FORGED STEEL BOLTED COVER PISTON CHECK VALVE**
**FIG. FPC-810F-150**  
**FIG. FPC-810F-300**

Design: API 602 – ASME B16.34  
 Testing: API 598  
 Flanges to: ANSI B16.5  
 Markings: MSS SP-25

**Materials:**

No.	Part Name	Specification
1	Body	ASTM A105N
2	Seat	Integral Hard Faced
3	Disc	A276 – 410
4	Spring	304SS
5	Gasket	Spiral Wound 304SS + Graphite
6	Cover	ASTM A105N
7	Cover bolt	ASTM A193 – B7

**Rating:**

Carbon Steel class 150 – 285 psig @ 100°F  
 Carbon Steel class 300 – 740 psig @ 100°F

**Note:**

- Other trims and body materials are available upon request.
- Integral HF seat.
- Regular port.

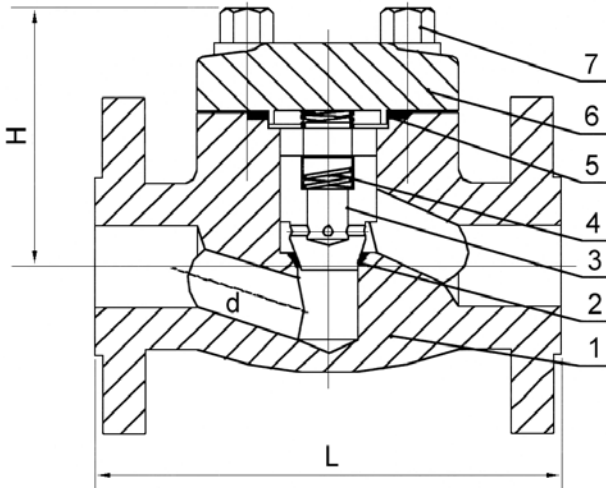
**Dimensions:**

Size		d		L				H		Weight			
				810F-150		810F-300				810F-150		810F-300	
in	mm	in	mm	in	mm	in	mm	in	mm	lb	kg	lb	kg
½	15	.39	10	4.25	107.95	6	152.4	2.40	61	5.94	2.7	5.94	2.7
¾	20	.51	13	4.6	116.8	7	177.8	2.40	61	6.82	3.1	8.14	3.7
1	25	.69	17.5	5	127	8	203.2	3.07	78	11.22	5.1	12.76	5.8
1¼	32	.91	23	5.5	139.7	8.5	215.9	3.31	84	14.96	6.8	17.16	7.8
1½	40	1.18	30	6.5	165.1	9	228.6	4.06	103	16.5	7.5	18.7	8.5
2	50	1.38	35	8	203.2	10.5	166.7	4.65	118	24.64	11.2	27.5	12.5