

---

**CLASS 150/300 FLANGED FORGED STEEL BOLTED COVER SWING CHECK VALVE**
**FIG. FSC-811F-150**  
**FIG. FSC-811F-300**

Design: API 602 – ASME B16.34  
 Testing: API 598  
 Flanges to: ANSI B16.5  
 Markings: MSS SP-25

**Materials:**

No.	Part Name	Specification
1	Flange	ASTM A105N
2	Seat	A276 – 410 Hard Faced
3	Disc	A276 – 420
4	Nut	304SS
5	Hanger Arm	F316SS
6	Pin	304SS
7	Pin	F13Cr
8	Body	A105N
9	Gasket	Spiral Wound 304 + Graphite
10	Cover	A105N
11	Cover Bolt	A193-B7

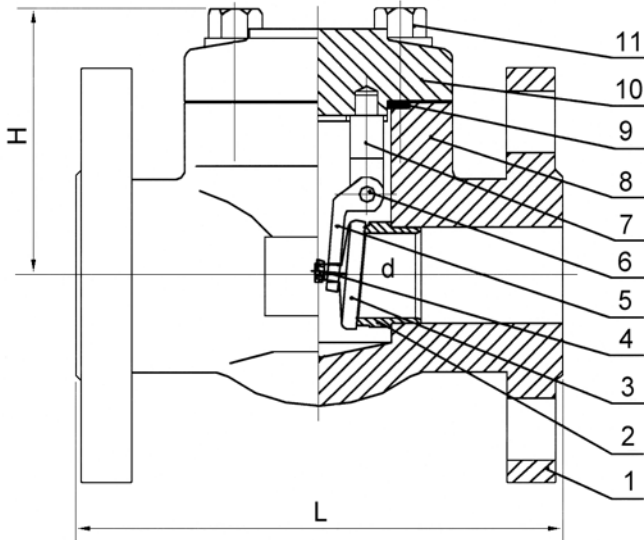
**Rating:**

Carbon Steel class 150 – 285 psig @ 100°F  
 Carbon Steel class 300 – 740 psig @ 100°F

**Note:**

- Other trims and body materials are available upon request.
- Integral HF seat.
- Regular port.

**Dimensions:**

Size		d		L				H		Weight			
				811F-150		811F-300				811F-150		811F-300	
in	mm	in	mm	in	mm	in	mm	in	mm	lb	kg	lb	kg
½	15	.39	10	4.25	107.95	6	152.4	2	51	5.64	2.56	5.94	2.7
¾	20	.51	13	4.6	116.8	7	177.8	2.4	61	6.48	2.95	7.70	3.5
1	25	.69	17.5	5	127	8	203.2	2.8	71	10.66	4.85	12.32	5.6
1¼	32	.91	23	5.5	139.7	8.5	215.9	3.23	82	14.21	6.46	16.50	7.5
1½	40	1.18	30	6.5	165.1	9	228.6	3.23	82	15.67	7.12	17.82	8.1
2	50	1.38	35	8	203.2	10.5	166.7	4.17	106	23.41	10.64	26.62	12.1